

DEVELOPMENT AND MODELING OF A BIOMECHATRONIC SENSOR EFFECTOR BOOT DEVICE

A. Platonov^{*}, L. Ilieva-Mitutsova^{**}, I. Chavdarov^{***}, N. Serbenyuk^{*},
O. Trifonov^{*}, V. Yaroshevsky^{*}

Abstract: *In this paper we represent the development of a sensor effector boot mechatronic device for effective rehabilitation of patients in the early post-traumatic stage (1 month) after the occurrence of a serious spinal-cord trauma or poli-trauma. The device is portable with insurance for vertical position in the bed of the immovable patients. The device includes: a module for basing and fixation of the patient's leg, a sensor "SkinTouch" for measuring bio-electrical impedance in points on the skin of the foot, a mechanism for acupressure, a module for basing of a measuring sensor and a mechanism for acupressure, and also gives the possibility for their connection to various foot points for the programme performance of the procedures and PC controlled sensor and effector elements, connected to the physician's monitor. In the paper are presented the design, modelling and experimenting of the separated modules. The studies are carried in Bulgarian Academy of Sciences - Russian Academy of Sciences collaboration advance to develop a new device for treatment of spinal patients and creating new technologies of their rehabilitation.*

Keywords: *boot mechatronic device, sensor, effector, rehabilitation, paraplegics.*

1. Introduction

Perspective and necessity of investigation on new sensors and effector mechatronic devices and technologies for locomotion rehabilitation are based on the results from the investigations on the physiological control locomotion mechanisms of humans and animals, performed in the Institute of Physiology "Pavlov" PAN (Gerasimenko et al., 1999), (Nikitin et al., 2001). Perspectives for a positive result of the rehabilitation at the locomotion pathology are derived in these investigations, as a result of a spinal cord trauma, main brain diseases or continuous muscle inactivity. At this stage a very important fact appears the application of the tactile feet stimulation of the injured limbs (Okhotsimsky, Nikitin, Gerasimenko et al., 2006). One of the methods of restoring the support-locomotion functions is to affect the neurons of the spinal cord using the limb reception system as a natural communication channel. Foot receptor activation is applied for that purpose. The study aim is to complete the following tasks: (i) to affect the extra receptors, which signals stimulate the central locomotion generator located in the spinal cord; (ii) to affect the nerve endings in the biologically active zones, stimulating the functioning of internal organs of a seriously disabled patient. The start of the procedure during the early post-traumatic stage (after the occurrence of a spinal cord trauma or poli-trauma) is considered to be appropriate for the decrease of atrophy speed. Due to patient's poor physical state, receptors stimulation is proposed at the start of recuperation procedure, only.

* Prof. Alexandr Platonov, DrSc: Keldysh Institute of Applied Mathematics, Russian Academy of Sciences, 4 Miusskaya Sq., 125047 Moscow, Russia, e-mail: platonov@keldysh.ru.

** Assoc. Prof. Lidia Ilieva-Mitutsova, Ph.D.: Assist.Prof. Vladimir Vitkov; Institute of Mechanics, Bulgarian Academy of Sciences, Acad. G. Bonchev str., bl. 4, 1113 Sofia, e-mail: lidia@imbm.bas.bg

*** Assoc. Prof. Ivan Chavdarov, Ph.D., Institute of system engineering and robotics, Bulgarian Academy of Sciences, Acad. G. Bonchev str., bl. 1, 1113 Sofia, Bulgaria, e-mail: ivan_chavdarov@dir.bg.

* Assis. Prof., Nicolay Serbenyuk, Ph.D.: Keldysh Institute of Applied Mathematics, Russian Academy of Sciences, 4 Miusskaya Sq., 125047 Moscow, Russia, e-mail: serb@keldysh.ru.

* Assoc. Prof. Oleg Trifonov, Ph.D.: Keldysh Institute of Applied Mathematics, Russian Academy of Sciences, 4 Miusskaya Sq., 125047 Moscow, Russia, e-mail: tov@keldysh.ru.

* Assoc. Prof. Viktor Yaroshevsky, Ph.D.: Keldysh Institute of Applied Mathematics, Russian Academy of Sciences, 4 Miusskaya Sq., 125047 Moscow, Russia, e-mail: yarosh@keldysh.ru.

2. Methods

Developed mechatronic module can ensure treatment procedures by foot receptor activation on method of acupressure, combined with methods of reflexotherapy. It operates according to a previously prescribed program for acupressure at specific foot points, receptor activation along specific trajectory or affects foot reflex areas.

The module can ensure control measure the bioelectrical resistance by means of a specialized sensor (Platonov et al., 2010) Such a sensor is needed to design a high-spatial resolution map of acupuncture points of a patient's foot, and the map should be used to analyze the results of the treatment. The sensor measuring both the initial (pre-treatment) foot skin electro-conductivity, as well as the current one operating during the process of medical treatment, is of essential importance for the successful stimulation of patient's foot.

Product "Mechanical Desktop 2005" is applied for the creation of a virtual 3D model of the module. The program "MSC.visualNastran 4D 2002" for computer simulation is applied on the 3D model.

3. Technical solution of mechatronic sensor effector boot device

The device includes:

- a module for basing and fixation of the patient's leg,
- a sensor "SkinTouch" for measuring bio-electrical impedance in points of the foot skin,
- a mechanism for acupressure,
- a carriage module for basing of a measuring sensor and a mechanism for acupressure,
- a module for a plane motion and positioning of carriage module to various foot points for the programme performance of the procedures,
- PC controlled sensor and effector elements, connected to the physician's monitor.

Four variants of the module for founding of patient leg, measuring and acupressure are developed and modelled (Ilieva-Mitutsova L., Chavdarov I., et al., 2011). The objective of the work presented in this paper is the development of the module variant IV, being the most suitable one for a portable device for application in a patient's bed when the patient being stationary.

The mechanical modules are designed in Institute of mechanics, BAS. The specialized a sensor "SkinTouch" for measuring bio-electrical impedance in points of the foot skin is developed in the Institute of Applied Mathematics "Keldysh"-RAN. Down are presented the design and modelling of the separated modules.

3.1. Design of a module for basing and fixation of the patient's leg

3.1.1. Requirements to module for basing and fixation of the patient's leg

The designed module must meet the following requirements:

1. Sustainable basing the patient's leg, which is in a bed.
2. An accessibility to be ensured to maximum number of points on the foot with the aim to measure the bioelectrical resistance by means of a specialized sensor.
3. Accessibility to maximum number of points on the foot for automatic acupressure performance according to a programme assignment, individually for each patient.
4. Discomfort must not be created to the patient, and also not to influence the precision of the carried out measurements.
5. Basing to be possible at different patient's feet sizes.
6. Safety of the patients to be ensured of the device activity at arising programme or mechanical reasons.

3.1.2. View of the module for basing and fixation of the patient's leg

The developed module includes the following component, (*Fig. 1*): 1- heel support, 2 - foot fixations, 3 - regulated foot fixing of the leg.

The foot is based at support 1. Fixations 3 are prepared for the leg fixed above the ankle joint and in the front part of the foot, which location is regulated longitudinally according to the foot size.

The surface of the foot remains uncovered for a direct contact to each point for measurement of the skin electrical resistance and acupressure.

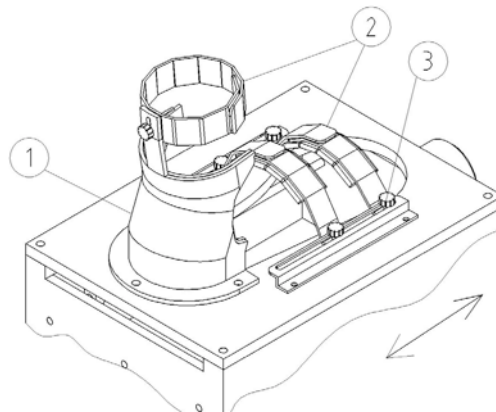

Fig.1: General view of the module for basing of the patient's leg

3.2. A carriage module for basing of a measuring sensor and a mechanism for acupressure

Combined module - carriage (Fig. 2.) comprises carriage 1, to which is immovably attached module for acupressure 2 and a measuring module 5. In the modules joints are included respectively two linear drives, by means of which a translation along axis Z is realised.

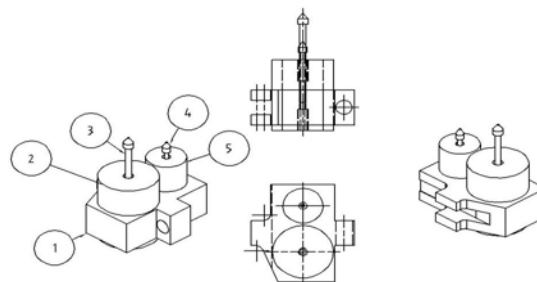

Fig.2: A carriage module for basing sensor and effector elements of device

The respective useful contact pressure of an electrode for measurement 4 is achieved by means of drive control and the external force (acupressure) is regulated by means of the executive mechanism 3.

3.3. A mechanism for acupressure

The mechanism for acupressure includes (Fig.3.) translation linear drive 1 and removable instrument with different number of pins 2 (Fig.4.).

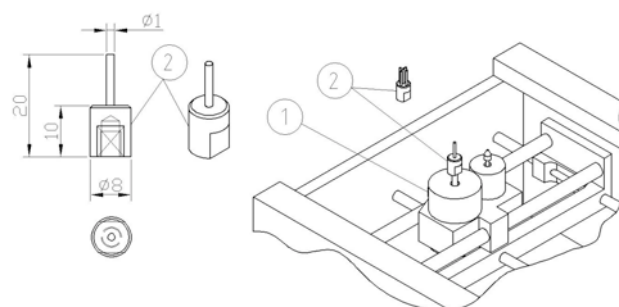

Fig. 3: A mechanism for acupressure

Effector instruments with different number of pins are applying for receptor activation by the method

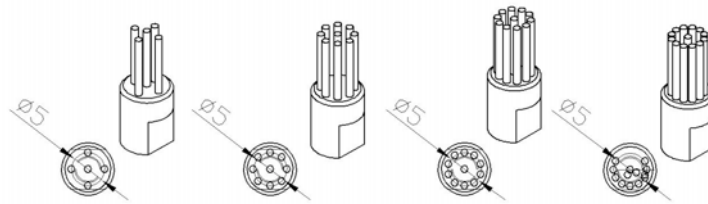

Fig. 4: Effector instruments with different number of pins

of skin-deep multi-pins acupuncture combined with methods of reflexotherapy.

3.4. Design and modelling of a module for a plane motion and positioning of carriage to various foot points

Movement along axes X and Y is realised by two mechanisms respectively (Fig. 5). The mechanism for longitudinal translation X includes: a foundation 1, a drive 2, a leading screw 3 and a guide 4 for translation along axis X. It is necessary, the run of this translation to be equal to the length of the foot $H_1 \approx 110$ to 150mm. The mechanism for translation along axis Y includes: a base-carriage 5, a drive 6, a gear 7 and a screw- carriage 9.

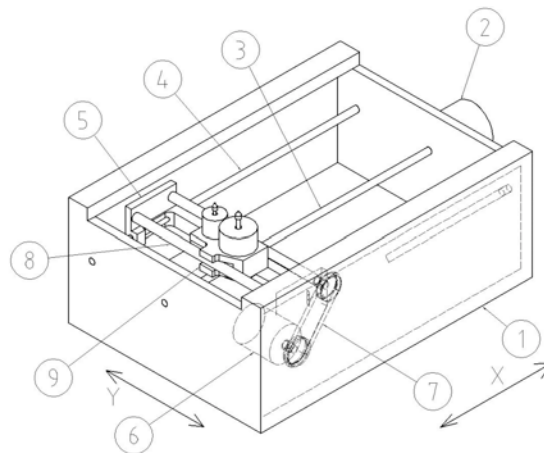

Fig. 5: A module for a plane motion and positioning of carriage

The drive 6 is fixed on the base-carriage 5 with by means of the gear 7 activates the screw- carriage 9. It moves by itself the carriage module 9 along axis Y lead on the guide 8. It is necessary, the translation run to be equal to the width of the foot $H_2 = L_p \approx 40$ to 60mm

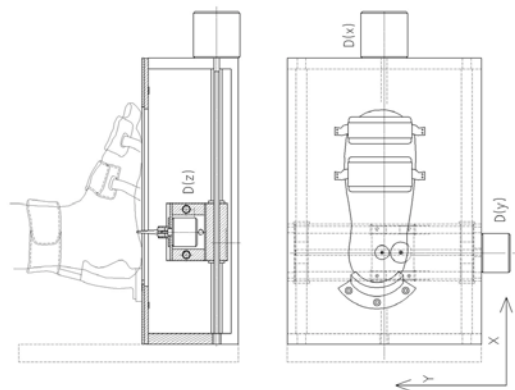

Fig. 6: Basing of the patient's leg for the programme performance of the procedures

The Fig.6. shows the basing of the patient's leg on the module gives the possibility for connection sensor and effector instruments to various foot points for the programme performance of the procedures.

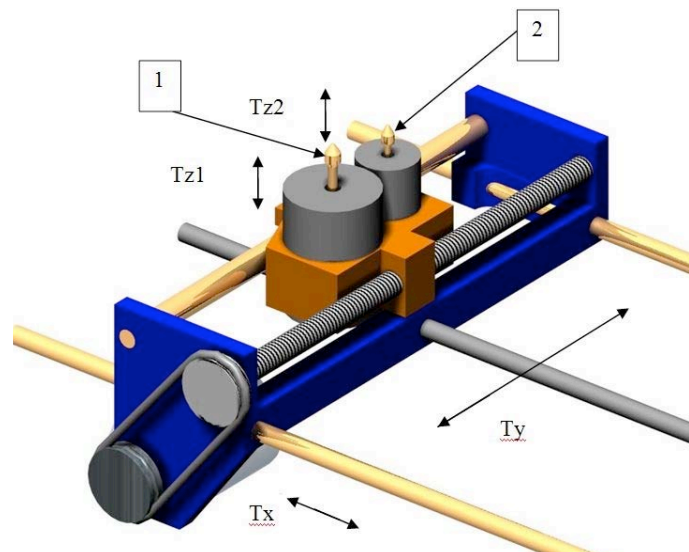

Fig.7: 3D model of mechanism for a plane motion and positioning of carriage for measurement and acupuncture

3.5 Development of the sensor “SkinTouch” for measuring bio-electrical impedance in a skin point

3.5.1 Proof of the design necessity of a specialized sensor for measuring bio-electrical impedance

The device measuring both the initial (pre-treatment) foot skin electro-conductivity, as well as the current one operating during the process of medical treatment, is of essential importance for the successful stimulation of patient's foot. Such a sensor is needed to design a high-spatial resolution map of acupuncture points of a patient's foot, and the map should be used to analyze the results of the treatment. The complexity of the registration needed originates in the measurement of current extremely low values. Note that current low value is due to the high ohm resistance of patient's foot skin, and to the restriction of voltage applied to patient's skin. That restriction is imposed to avoid not only injury or pain, but also data distortion due to the effect of voltage of the measuring instrument over the physiology of controlled processes.

A mechatronic approach for the measurement of human skin electro-conductivity is developed in the Institute of Applied Mathematics “Keldysh”-RAS (Platonov A. et al.,2010). The measurement method proposed is based on the use of a differential operational amplifier, controlled by a microprocessor. It is capable of maintaining stable ultra-small current (not larger than several μA) in the chain of the analogue-digital analyzer (ADA) of the skin resistance receptor. Signals coming from an analogue-digital converter (ADC) are used to apply microprocessor control of measurements. The ADC is switched to a differential operational amplifier. A special measuring device “SkinTouch” is designed to realize the software algorithms and analyze the capabilities of the proposed method. It is assembled using modern electronic compounds and schemes that guarantee the measurement accuracy required.

3.5.2. Technical description of the sensor “SkinTouch”

The basic function of the sensor device “SkinTouch”, is to perform point measurements of the human skin resistance characteristics. Among its technical characteristics, one should note the ultra-low current of measurement, from 0,5 to 2 μA , and the moderate potential difference (voltage) applied to the electrodes and not exceeding 7 V. Those characteristics exceed twice the characteristics of the existing equipment. They enable one to significantly decrease the measurement pattern distortion and minimize the unfavourable effects over the patient.

3.5.2.1. Requirements to the measurer of resistance characteristics

Methodically, the instrument for measurement of the resistance characteristics of human skin should satisfy the following requirements:

1. Measurements should be performed using low current in the range $0,1 - 1 \mu\text{A}$.
2. Current value should be constant during measurement.
3. The measurable parameter should be the difference between the electrode potentials.
4. The working voltage between the electrodes should be within the range $[0,1 - 1] \text{ V}$.
5. The maximal admissible difference between the electrode potentials should be 15 V .
6. The measurements performed should minimally affect patient's state.

Note that the designed sensor device "SkinTouch" satisfies the outlined requirements.

3.5.2.2 Principal scheme of the "SkinTouch"

The principal scheme of the measuring device "SkinTouch" is shown in Fig.7. The device basic compounds are:

- Microcontroller;
- Measuring unit;
- Generator unit;
- Supply sources.

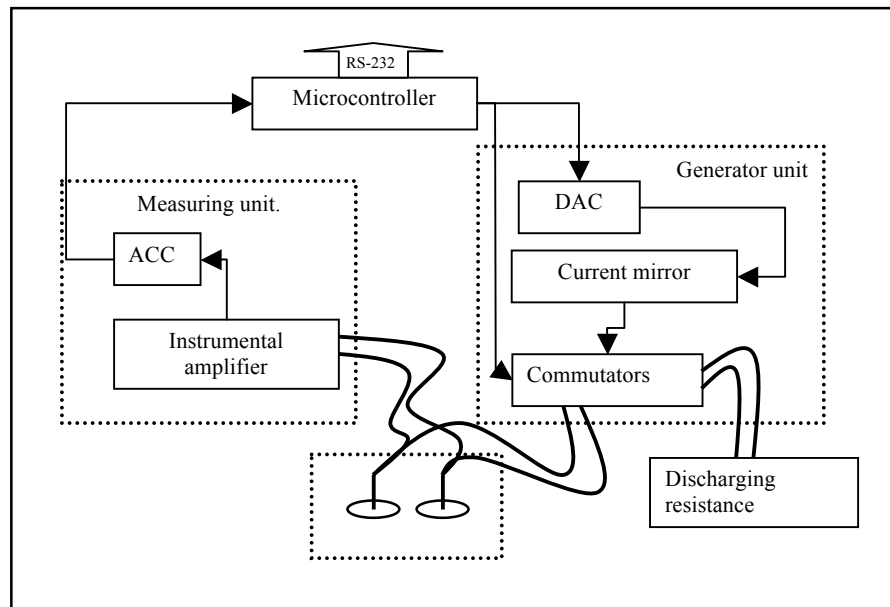

Fig.8: Principal scheme of the measuring device "SkinTouch"

The microcontroller coordinates performance of all other units, transition of measurement results to other devices along the channel RS-232, as well as receives of controlling commands.

The measuring unit consists of:

- Instrumental operational amplifier, with small value of leak current and incorporated means of protection against electrostatic discharges;
- Analogue-digital converter incorporated into the microcontroller

The generator unit consists of:

- Digital-analogue converter with current output, which provides the necessary range of the supporting current.
- Current mirror which exactly copies the supporting current of the ADC within the range of the electrodes supply voltage. The commutation unit is used to eliminate the electrode polarization.

The direction of current flowing between the measuring electrodes can be varied upon an order issued by the microprocessor. The unloading resistance is used for calibration and discharge of the electrode static charge.

Two direct current sources are used to supply the measuring device “SkinTouch”. The first source, with voltage 3,5 V, is used to supply the instrument digital section. The second source provides two voltage values: + 3,5 V and – 3,5 V, and it supplies the instrument analogue section. Batteries or accumulators are used to reduce disturbances.

A prototype of the measuring device “SkinTouch” is assembled, and instrument tests are performed.

8. View and modelling of the sensor effector boot device

Product *Mechanical Desktop 2005* is applied for the creation of a virtual 3D model of the module.

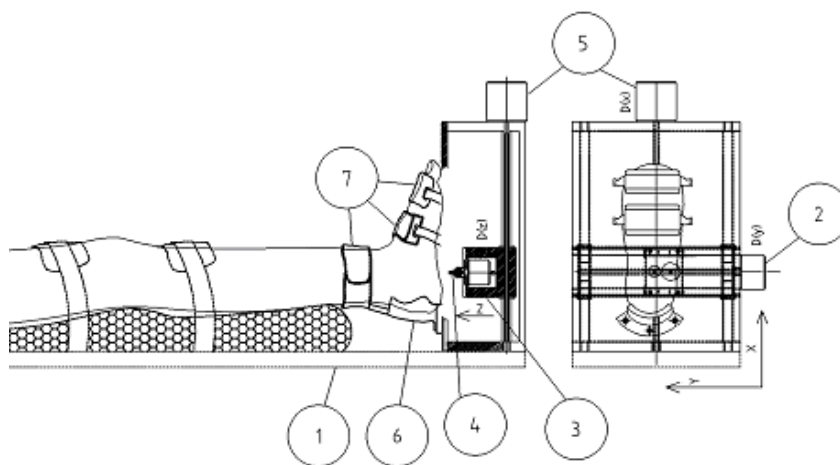

Fig.9: General view of the device in the bed of the immovable patient

The module components are following: 1- base, 2 - translation linear drive along axis Y, 3 - combined module-carriage, 4 - executive mechanism for acupuncture, 5 - translation linear drive along axis X, 6 - heel support, 7 - foot fixations.

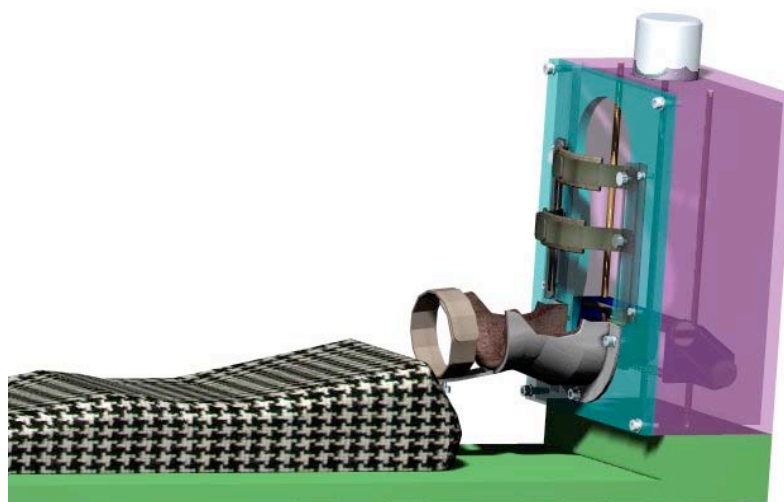

Fig.10. 3D model of a mechatronic sensor effector boot device

Module functions simulation is performed on the derived 3D model of the new device.

9. Conclusions

The conclusions derived after modelling and simulation help the successful realization and approbation of the separate modules and the prototype of the new device.

The program is derived for the performance of the rehabilitation healing by means of the new portable mechatronic device. It is as follows:

1. Measuring the bioelectrical resistance to be performed in the foot points for each individual patient by means of a specialized sensor "*Skin Touch*". An individual chart of the acupuncture foot points of the patient is build up.
2. Planning and performing of treatments (acupresura) in definite points, along a defined trajectory or on a foot area.
3. Performing a periodical estimation and control of the treatment results by means of measuring of the bioelectrical resistance in definite foot points. The healing programme undergoes a consecutive variation, if necessary.

Clinical tests are going to be performed for assessment the efficiency of the new technology for rehabilitation of patients with spinal-cord trauma by means of the application of the new mechatronic boot device in the patient's bed within the frame of the first month after heavy damage. The results are valued in two directions:

- for the fundamental science, which investigate the adaptive processes and control of human locomotion, at absence of a link with the high regions of the nervous system after a trauma disconnection;

- for the rehabilitation practice, at a proved positive effect it is possible a routine application of the new technical device and technology of locomotion therapy.

Acknowledgement

This work was supported by a Bi-lateral project of BAS and RAS "Creation of new sensor and effector mechatronic devices for rehabilitation the locomotion abilities of the spinal cord of patients with a spinal-cord pathology" and Institutional Research Plan of IMECH of BAS.

References

- Gerasimenko, Yu., Avelev, V., Makarovskiy, A. et al. (1999) Neurokontrol of central pattern generator by means of epidural spinal cord stimulation. In: *From the Basic motor Control to Functional Recovery* (N. Ganchev and G. Ganchev eds), Publishing House of BAS Prof. M. Drinov, Sofia, pp. 484-488.
- Nikitin O., Gerasimenko Yu. et al. (2001) Features of CPG activation in chronic spinalized cats under spinal cord stimulation, in: *Sensoriomotor control* (A. Kosev ed.), NATO, Scientific Affairs Division, LOS Press, 172-179.
- Ilieva-Mitutsova L., Chavdarov I., Vitkov V., Yaroshevskiy V., (2011) A mechatronic module modeling for foot receptor activation, in: *Proceed. of Inter. Conf., Engineering Mechanics 2011*, (V. Fuis ed.), Inst. of Thermomechanics, ASCR, Prague, pp. 231-234.
- Okhotsimskiy D., Nikitin O., Gerasimenko Y. et al. (2006) A biomechanical stimulator for scientific-experimental study of the regeneration of spinal cord locomotion capabilities after traumatic break, in: *Proceed. of Inter. Conf. "Advanced Problems in Mechanics 2005", Minisymposium on Biomechanics*, (Nyashin Y. ed.), St. Petersburg, 394 – 400.
- Platonov A., Vitkov V., Inieva-Mitusova L., Serbenyuk N., Trifonov O., Yaroshevskiy V. (2010) A high sensitivity device for measuring bio-electrical impedance of human skin, in: *Proceed. of Inter. Conf. "Advanced Problems in Mechanics 2010"*, <http://apm-conf.spb.ru>, St. Petersburg.