

MAIN PROBLEMS OF CUTTING SPIRAL BEVEL GEARS WITH DUPLEX HELICAL METHOD

M. Płocica*, Z. Wójcik*

Summary: *The paper concerns the main problems which appear during cutting spiral bevel gear according to Spiral Generated Duplex Helical method. The geometrical solutions and mathematical dependences which were based on the geometrical method were presented.*

1. Introduction

Duplex Helical method for producing spiral bevel gears is a rapid and economical method for producing accurately finished ring gears. With this method the gear tooth is cut single-cycle: both sides of the tooth space are finished at the same time. Cutting full depth of tooth space is realized at the single setting of the machine. The cutter used is of the circular face-mill type with alternate inside and outside cutting blades, the radial distance between the last two blades (point width) being such as to produce a tooth space of the desired width.

There are three variations of the Duplex Helical Method:

- SPIRAL GENERATED DUPLEX HELICAL (SGDH)
- SPIRAL FORMATE DUPLEX HELICAL (SFDH)
- HYPOID FORMATE DUPLEX HELICAL (HFDH)

Problems which are discussed below concern the processing according to SGDH method. The main advantage of this method (in comparison with SFDH and HFDH) is possibility of grinding teeth after heat treatment. Because of envelope character of this processing, grinding burns don't appear. The possibility of Duplex Helical method processing is limited by the necessity of possessing such machine which is equipped with a mechanism which guarantee the helical motion in the process of generation. These are: 102, 106, 116, 122, 645 and GMAX2010 machines. It is possible to cutting gear by Duplex Helical Method in Poland in the following industrial centre: „Maszyny Elektryczne CELMA S.A.” in Cieszynie (102 machine), „POLMO Gniezno, sp. z o.o.” (GMAX 2010), Fabryka Lokomotyw Chrzanów (122), HSW Stalowa Wola (645).

Although Duplex Helical Method has been used for over forty years, the theoretical assumptions which enable comprehensive design of production process hasn't been revealed. Gleason marketing policy offers the results calculations of the production technology for the

* M. Sc. Mieczysław Płocica, Prof. D. Sc. Zdzisław Wójcik: Department of Machine Design, Rzeszów University of Technology, ul. W. Pola 2, 35-959 Rzeszów, Poland; tel.: +48 0103317 865 16 40, fax +48 0103317 865 11 50; e-mail mplocica@prz.rzeszow.pl

specific order. Calculation instructions are published in encrypted form and the physical sense of the calculated values is hidden. Because of this, it is advisable to present a report which concerns solved problems and the theoretical assumptions which allows to produce bevel gears by Duplex Helical Method.

2. Data required for technological calculations

In order to perform technological calculations, it is necessary to have the following data given:

z_1, z_2 - the number of teeth in the pinion and the gear respectively

m_t - outer transverse module

b - face width

R_a, R - outer and mean cone distances

α - normal pressure angle,

β - mean spiral angle,

Σ - shaft angle

δ_1, δ_2 - pitch angles of the pinion and the gear respectively,

δ_{f1}, δ_{f2} - root angles of the pinion and the gear respectively,

θ_{f1}, θ_{f2} - dedendum angles of the pinion and the gear respectively

C - clearance

h_{a1}, h_{a2} - mean addendums of the pinion and the gear respectively

h_{f1}, h_{f2} - mean dedendums of the pinion and the gear respectively

d_{ea1}, d_{ea2} - outer diameters of the pinion and the gear respectively

3. Head cutter determination

During cutting the teeth by SGDH method the constant width of bottom land of a gear is obtained. It is the representation of the head cutter blade trajectory. Theoretical radius of the head is determined from the formula below:

$$r_0' = \frac{R \sin \beta}{1 - \frac{2 \operatorname{tg} \alpha \cos \beta \cdot \theta_{f\Sigma} R_a}{10800 m_t}} \quad (1)$$

where: $\theta_{f\Sigma} = \theta_{f1} + \theta_{f2}$ - the sum of the dedendum angles of the pinion and gear

The radius of the real cutter should be chosen (by adjusting of the shin) in precise 0,01". It should be known that the cutter heads up to 4 1/2" diameter they are usually made as a monolith (without possibility of regulation). In this case, the difference between the required r_0' and standard cutter head radius r_0 is compensated by a change in the cone distance of the generating gear.

$$\Delta R = \frac{R \left(1 - \frac{2 \operatorname{tg} \alpha \cos \beta \cdot \theta_{f\Sigma} R_a}{10800 m_t} \right) \left(\frac{r_0 - r_0'}{r_0} \right)}{K} \quad (2)$$

where

$$K = 1 - R \sin \beta \left(\frac{1}{r_0'} - \frac{1}{r_0} \right) \quad (3)$$

We can get in this way:

$$R + \Delta R = R_M \quad (4)$$

where: R_M is technological cone distance

4. Tooth bearing contact bias and its elimination

With the Gleason's system the tapering depth causes changes in the pressure angles going from the middle towards the end of the teeth, a condition called a bias (see Fig. 1).

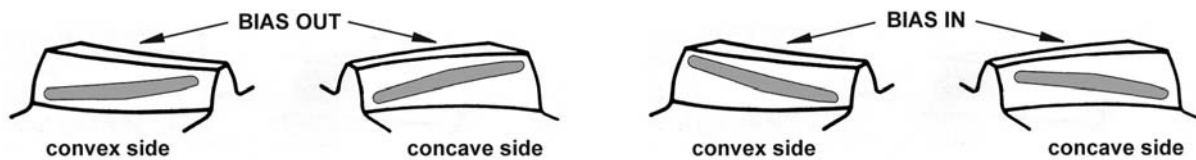

Figure 1 Bias out and bias in on both sides of the tooth

If both sides of the tooth space are to be finished at the same time, the bias can only be eliminated by improving the helical motion. Kinematics of helical motion is shown in Figure 2.

Both, theoretical consideration and practice show that using helical motion in the process of generation is the only one effective way to eliminate bias in this method. The helical motion is added only during pinion finishing but the teeth of the large gear are finished without the helical motion.

With the helical motion, the angle of deflection from the pressure angle, expressed in minutes of arc, is defined by the following formula resulting from gear geometry and the assumed diameter of the head cutter:

$$\alpha_x = \frac{\frac{\theta_\Sigma (R + \Delta R)}{r_0} - (\theta_\Sigma - \theta_{2M}) \sin \beta}{\cos^2 \beta} + \Delta \alpha_x(r_0) \text{ ["} \quad (5)$$

In this formula the $\Delta \alpha_x(r_0)$ value is a consequence of the assumption that the normal radius of the cutter is different from the calculated radius r_0' . The corrected angle is calculated as follows:

$$\Delta\alpha_x = \frac{\Delta R \sin \beta (tg \delta_1 + tg \delta_2)}{R tg \alpha} \left(1 - \frac{2 tg \alpha \cos \beta \cdot \theta_\Sigma R_a}{10800 m_t} \right) \left(\frac{r_0 - r_0'}{r_0} \right) \cdot 3440 \text{ ["} \quad (6)$$

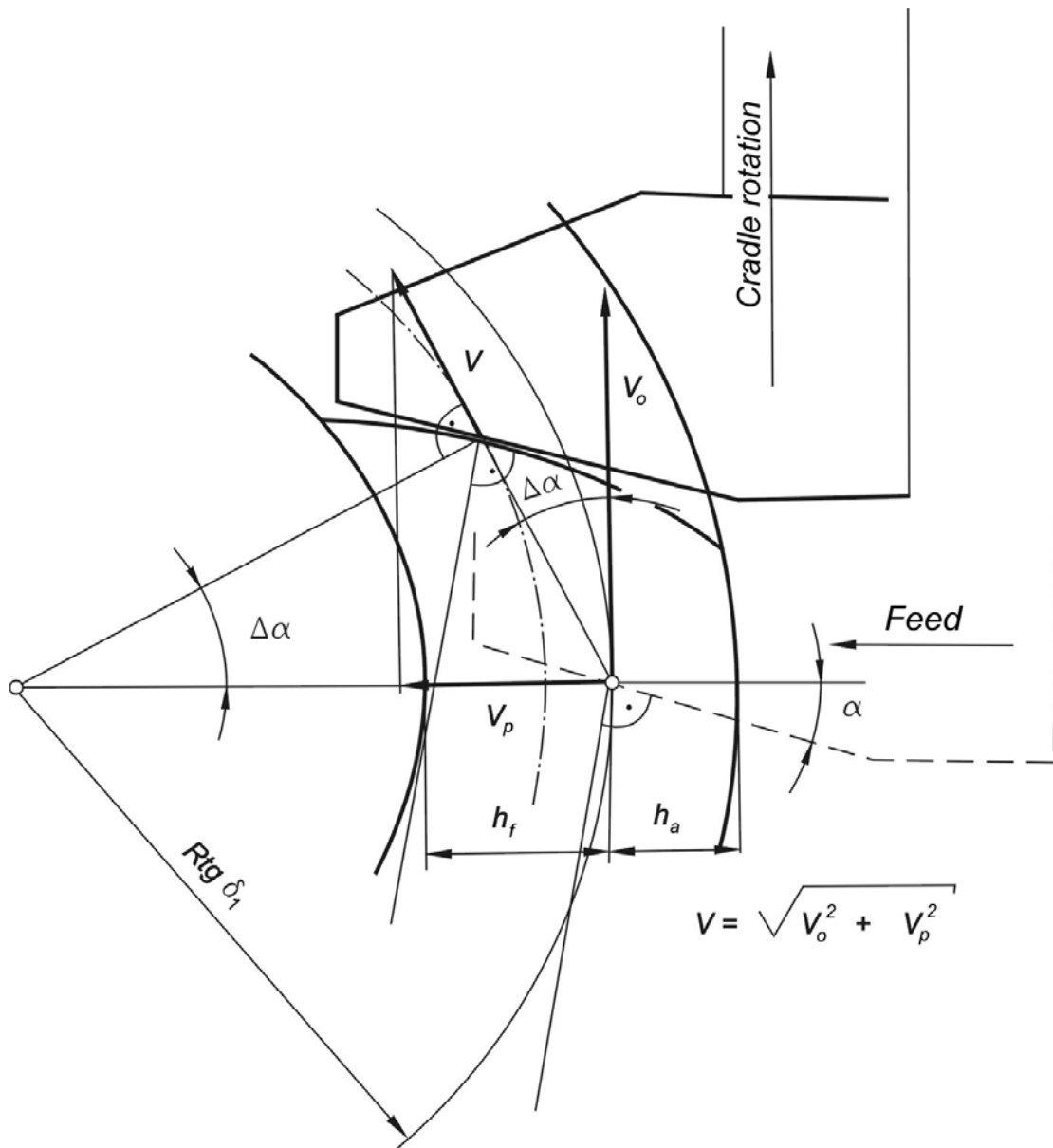

Figure 2 Kinematics of helical motion

The helical motion causes a change in the generating gear angle, making it necessary to introduce a hypoid offset for pinion finishing. Construction for determination of the value of hypoid offset (a_{M1}) is shown in Figure 3.

The angle of the pinion generating gear (according to Fig. 4) is defined as follows:

$$\sin \delta_{M1} = \cos \alpha_x \sin \delta_{f1} - \sin \alpha_x \sin \beta \cos \delta_{f1} \quad (7)$$

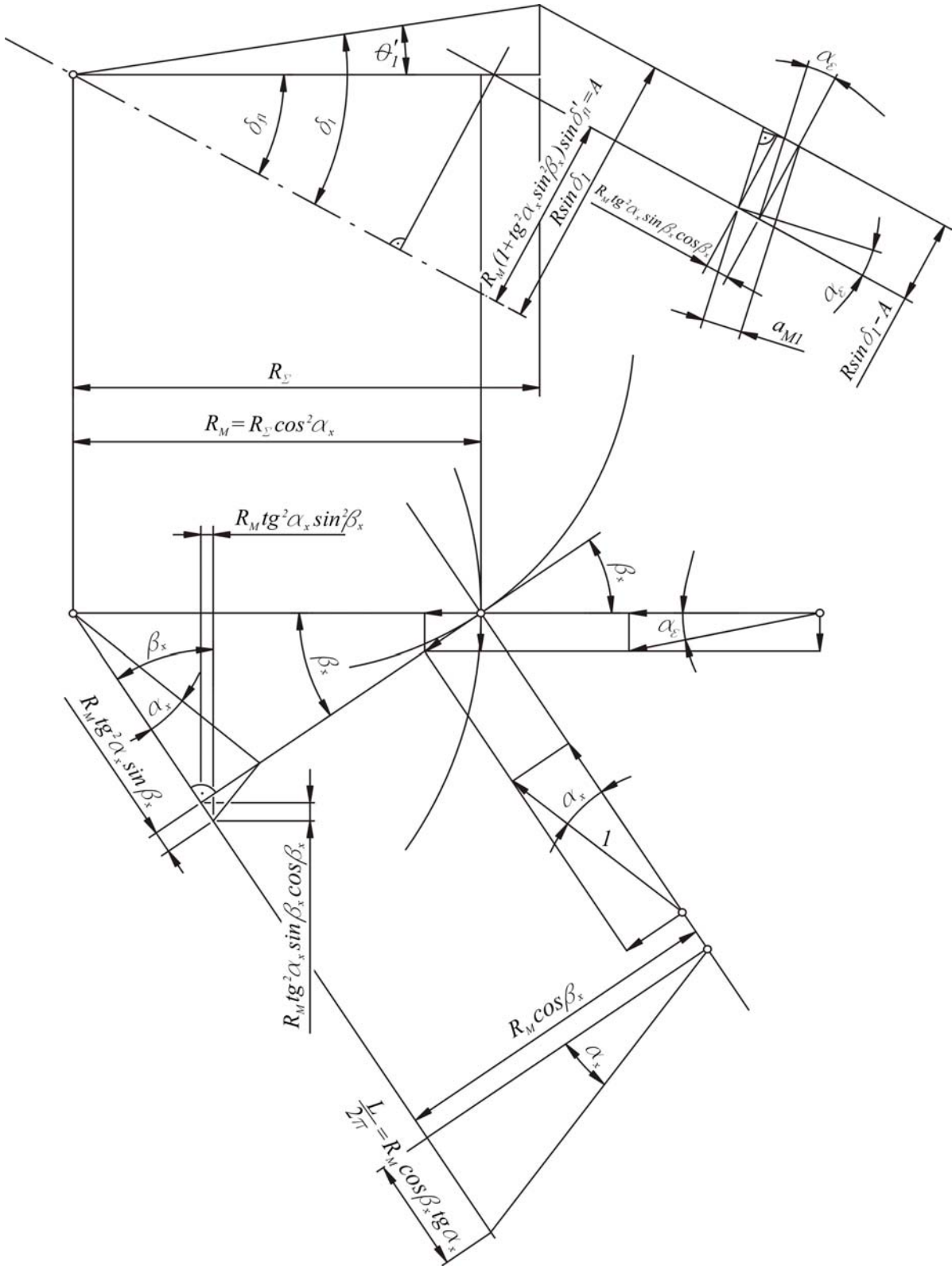

Figure 3 Construction for determination of the hypoid offset and the helical motion parameters

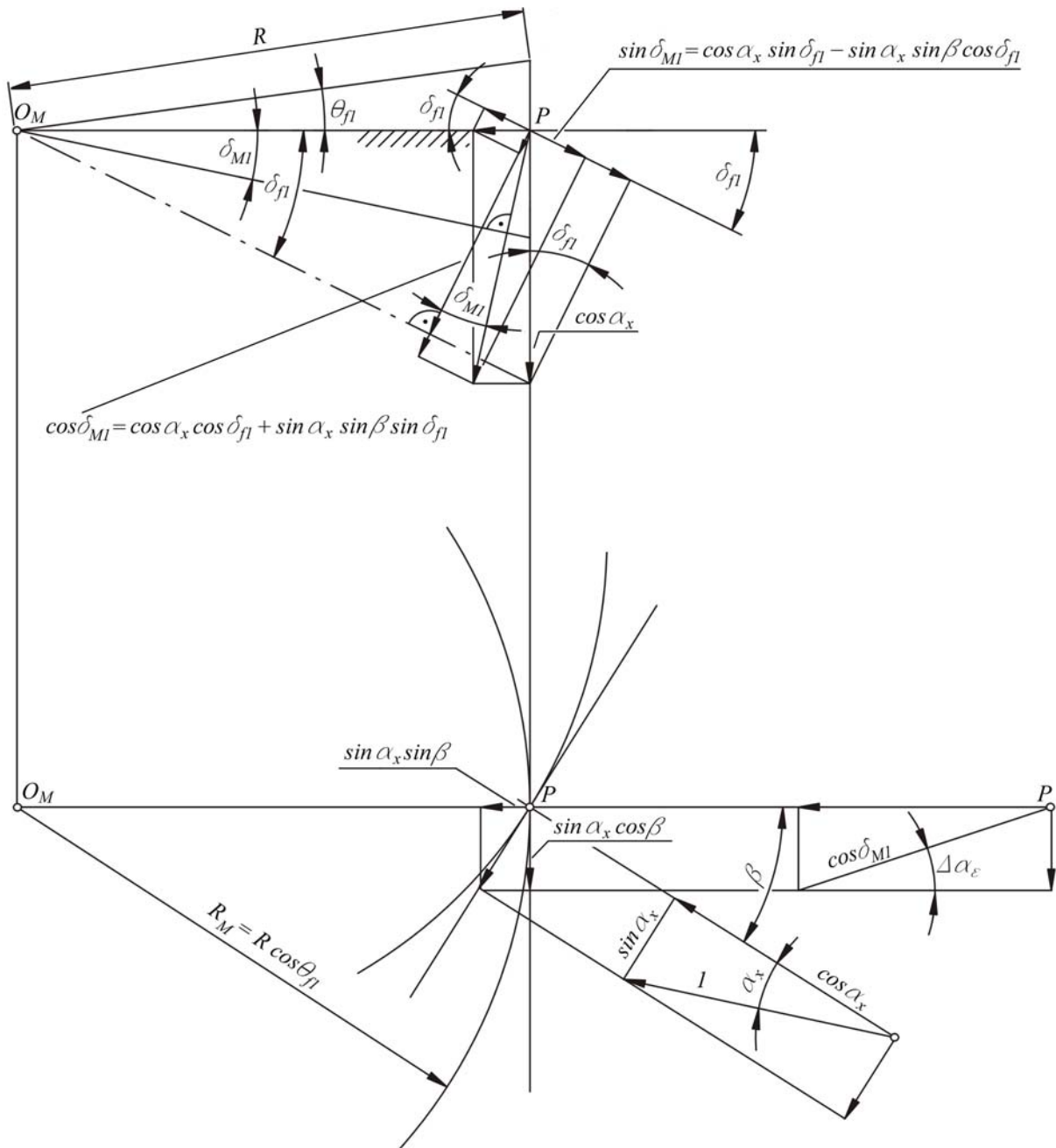

Figure 4 Construction for determination of the angle of the pinion generating gear

The helical motion will produce a difference between the inside and outside blade angles $\Delta\alpha_\epsilon$, which is a result of the hypoid offset in the pinion finishing system. The difference is determined as follows (see Fig. 4):

$$\sin \Delta\alpha_\epsilon = \frac{\sin \alpha_x \cos \beta}{\cos \delta_{MI}} \quad (8)$$

The helical motion index (see Fig. 3) is calculated according to the formula:

$$p = \frac{L}{2\pi} = \cos \beta \cdot \operatorname{tg} \alpha_x \cdot R_M \quad (9)$$

and the spiral lead is equal to:

$$L = 2\pi \cdot R_M \cdot \operatorname{tg} \alpha_x \cdot \cos \beta = 2\pi \cdot R_M \cdot \operatorname{tg} \alpha \quad (10)$$

4. Conclusion

Problems discussed above are fundamental for understanding the geometry of teeth shaping in spiral bevel gears in Gleason system. Nowadays, the complete system of technological calculation is being elaborated. This system will allow to design technology for spiral bevel gears cutting by Duplex Helical Method apart from Gleason Works Company.

5. References

- Dudley Darle W. (2000) *Handbook of Practical Gear Design*, CRC Press, New York.
Wójcik Z. (1984) *Przekładnie stożkowe. Konstrukcja i technologia*, WNT, Warszawa.
Wójcik Z. (1993) *Obrabiarki do uzębień kół stożkowych*, WNT, Warszawa,
Wójcik Z., Płocica M. (2001) Dobór głowicy nożowej do obróbki kół stożkowych o zębach kołowo-lukowych nacinanych metodą Duplex Helical, in. *Zeszyty Naukowe Politechniki Rzeszowskiej, Seria Mechanika*, z. 57, Rzeszów.
Generated Spiral Bevel Gears DUPLEX – HELICAL Method. (1965) Gleason Works, Rochester, USA.