

## **SIMULATION OF VEHICLE TRACK DYNAMIC LOADING**

**M. Chalupa<sup>1</sup>, R. Vlach<sup>2</sup>**

**Abstract:** *The contents of article describes design of the vehicle track computational model and example of testing procedure of the track dynamic loading simulation. The proposed approach leads to an improvement of track vehicle course stability. The computational model is built for MSC. ADAMS, AVT computational simulating system. Model, which is intended for MSC computational system, is built from two basic parts. The first one is represented by geometrical part, while the second one by contact computational part of the model. The aim of the simulating calculation consist in determination of change influence of specific vehicle track constructive parameters on changes of examined qualities of the vehicle track link and changes of track vehicle course stability. The work quantifies the influence of changes of track preloading values on the demanded torque changes of driving sprocket. Further research possibilities and potential are also presented.*

**Keywords:** *tracked vehicles, track, computational simulation, dynamic loading simulation.*

### **1. Introduction**

Presented research analysis the problem of bad course holding of specific track vehicle when driven at a speed exceeding 65 km.h<sup>-1</sup>. It is possible to identify the reasons of this effect and to propose potential possibilities of its elimination (Chalupa, 2001). Proposal of the design changes that would enable the safe increasing of the maximum vehicle speed is desired and would be very useful for practical use.

This problem can be solved by use of mathematical computer simulation (Rolc, 2008) and (Chalupa, 2007). It is necessary to built the mathematical model of the examined object, and powerful computing simulating system must be available (Chalupa, 2007) and (Koucký, 2011). The mathematical model described in this work is built for modelling in MSC.ADAMS.AVT computational system (ADAMS/MSC, 2003) and (Chalupa, 2007). The ambition of this work is to create a generalised computational model usable not only for the simulation of vehicle track but also for the general vehicle undercarriage dynamic properties. The results of such modelling could be practically used in mathematical modelling and analysing of individual undercarriage parts behaviour during vehicle ride. It is necessary to define the main possibilities of track vehicle course holding improvement by simultaneous increase of maximum speed vehicle.

The first part of the simulation is focused on collecting the data on undercarriage design parameters under different vehicle course holding conditions and increasing maximum speed. These preliminary simulations are focused on monitoring of the influence of changes in supporting axes reaction forces in relation with changes of track links weight and initial tension of track. Such changes can influence the general vehicle course holding. It is well known that design parameters have relevant influence on dynamic loading of some undercarriage parts. The complete calculation of this influence is subject of the second part of the presented work. Following part of the simulation is focused on

---

<sup>1</sup>Assoc.Prof. Milan Chalupa, MSc. CSc., Department of Mechanical Engineering, Faculty of Military Technology, University of Defence, Kounicova 65, 662 10 Brno, Czech Republic, [milan.chalupa@unob.cz](mailto:milan.chalupa@unob.cz) [www.unob.cz](http://www.unob.cz)

<sup>2</sup> Assoc. Prof. Radek Vlach, MSc. Ph.D..Institute of Solid Mechanics, Mechatronics and Biomechanics, Faculty of Mechanical Engineering, Brno University of Technology, Technická 2896/2, 616 69 Brno, Czech Republic, [vlach@uvee.fee.vutbr.cz](mailto:vlach@uvee.fee.vutbr.cz) [www.vutbr.cz](http://www.vutbr.cz)

determination of possible changes of sprocket wheel torque in relation with changes of initial tension of track. According to torque required on driving wheel (absorbed to override the resistance of the vehicle track), it is possible to determine other parameters of undercarriage design, that are greatly affecting maximum vehicle speed.

The paper presents possible modeling method for the selected type of vehicle track in point two and results of simulating computer modeling of vehicle track dynamic loading performed by vehicle running in point three.

## 2. Computational model

The computational simulating system MSC.ADAMS.AVT is used for the computational modelling and simulating. This system can be used for the analysis of kinetic and dynamic characteristics of the modelling mechanic system and its animation. Model intended for MSC computational system must be built from two basic parts. These parts of the model are: geometrical and contact computational parts (ADAMS/MSC, 2003). Geometrical part of computational model must consists of basic parts of the vehicle undercarriage movable parts. The model involves road wheels (Fig. 1), supporting rollers, driving sprocket (Fig. 2), idle wheel and track line on which individual track links are connected by couplings (Fig. 3). The parts are defined by components with real geometrical shape. The critical aspect at this point is to keep the flat contact.

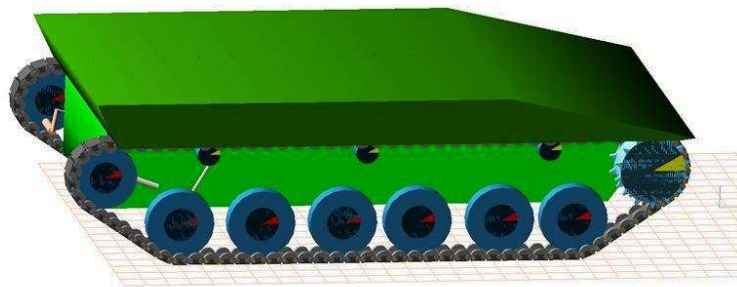

Figure 1: Geometrical part of computational model

The main parts of the track link are as follows: the body with two guiding detents and two connected eyes with pins, couplings, and retaining screws. There are 84 track links on each track.

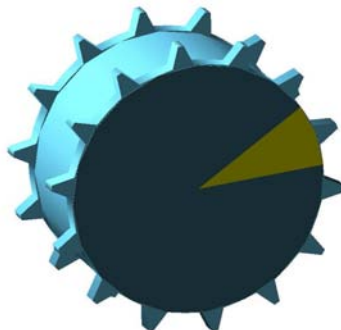

Figure 2: Geometrical model of the sprocket wheel

Axel arms, shock absorbers and torsion bars are defined as simplified shape components, thus without contact components. This type of the components is generated from the offer of universal track vehicles undercarriage components. They are defined by input data such as basic design dimensions, weight, moment of inertia, stiffness, absorbing and number of parts.

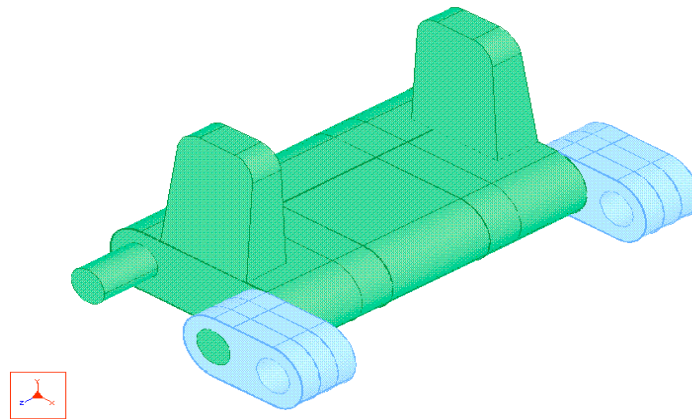

Figure 3: Geometrical model of the track link and connecting clip

Contact part of computational model must involve impact and frictional forces system (ADAMS/MSC, 2003). To guarantee the highest accuracy and practicality, the impact and frictional forces of the individual undercarriage parts are defined in such way (Vlach, 2008), that the whole model resembles the reality as much as possible. These contact forces are described in Adams System by impact force Eq. (1):

$$F = -k'(q - q_0)^n - cq' \quad (1)$$

where:  $q - q_0$  - penetration of bodies in contact,  $k$  - contact stiffness,  $c$  - damping coefficient,  $q'$  - sliding velocity of bodies in contact,  $n$  - stiffness force exponent

Contact model is described by characteristic of sliding velocity influence on friction coefficient (Fig. 4), (Chalupa, 2007) and (Vlach, 2008).

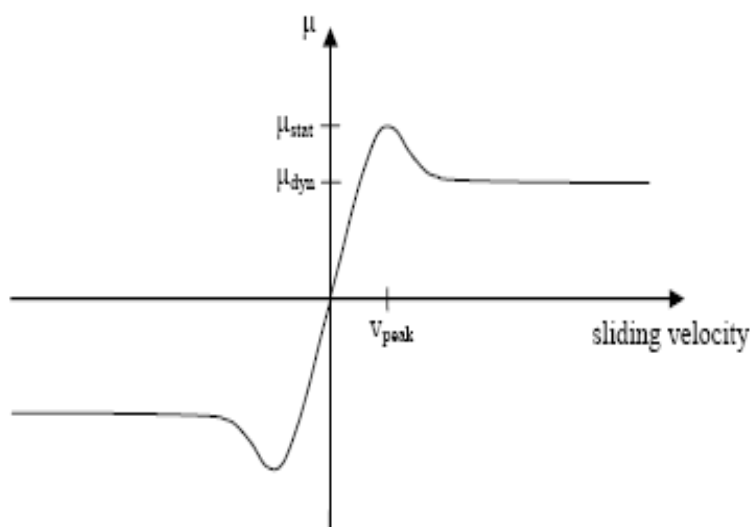

Where:

$\mu_{stat}$  - static friction coefficient,

$\mu_{dyn}$  - dynamic friction coefficient

Figure 4: Course of friction

### 3. Results of calculation

The aim of the simulating calculation to determine the influence of change of specific vehicle track constructive parameters on changes of examined qualities of the vehicle track link. These are determined especially by intensity changes of the reaction force of the carrying elements of track links bodies.

The ten of tested parameters are radius of driving wheel, radius of tightening wheels, initial tension track, weight of track link, stiffness of connection plugs track link, resistance against turning of clutches plugs link, geometry of driving rib of track link, weight of bearing rollers, radius of bearing rollers, stiffness of assessment of base of bearing rollers.

Simulation calculations were performed with using of computation model displayed in figure 1. As can be seen from introduced example in graph 1, reduction of the initial torsion of track for about 10 000 Nm causes decrease of required torque value from 10 181 Nm to 9 369 Nm. It represents approximately 7.5 %. Increasing of initial track tension for about 10 000 Nm causes increasing of required torque value from 10 181 Nm to 13 553 Nm, which is about 33 %. It is thus possible to conclude that there is a big influence of changes in initial torsion of track on driving sprocket required torque.

Graph 1: Course of required torque moment values on initial track torsion

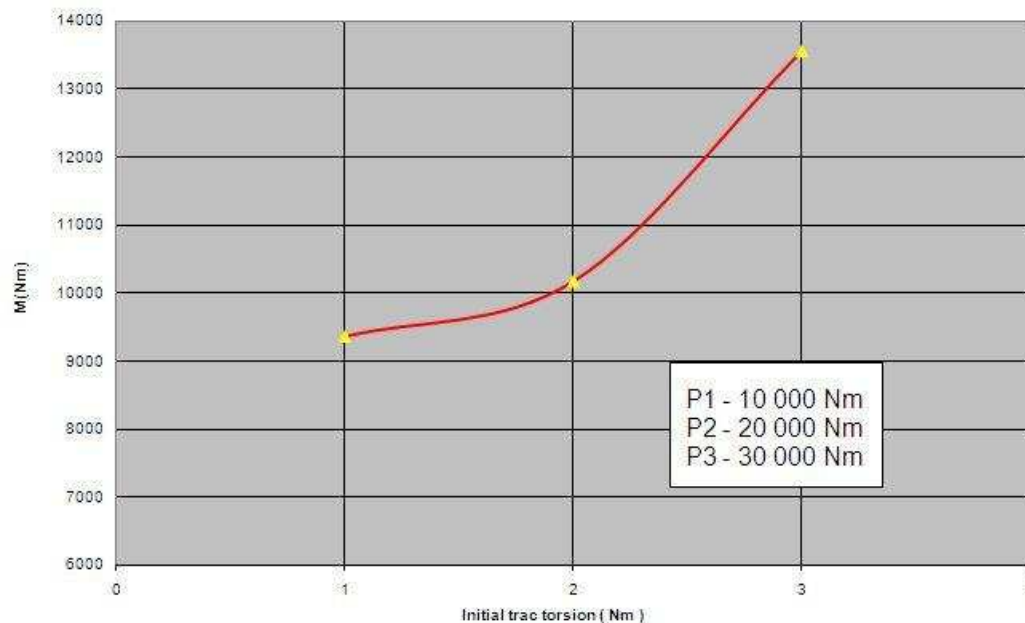

This parameter influences vehicle course holding and improves maximum speed of the vehicle. It seems to be very promising and important to perform the full analysis of this phenomenon (influence of this design parameter) in the future. The results of previously performed basic simulating calculations shown the big influences of changes in reaction forces supporting rollers axes on changes of track links weight and initial tension of track. It is clear that this design parameters have big influence on dynamic loading of some undercarriage parts and therefore a maximum speed of vehicle. The same influence of changes of required torque on sprocket wheel in relation with changes of driving sprocket diameter were approved as well. This parameter influences vehicle course holding and improves maximum speed of the vehicle. This phenomenon will be the subject of our forthcoming research when full calculation will be performed.

#### 4. Further research plans

Application of the advanced simulation will be performed as a consequent step with the aim of assembling the approximation relation  $y_0$  of monitored parameters  $R_x$ ,  $F_{pr}$ ,  $k_p$  a  $m_x$ .

1. Composite plan simulations assembly for 4 parameters (Vlach, 2008).
2. Implementation of 24 simulating calculations according to composite plan.
3. Assesment of regression function

According to proposed model simulations, it is possible to derive the approximation relation (regression function) formulating the dependence of element velocity on above mentioned factors, which are easy to determine. Created regression quadratic model has a following form (in relation to variables):

$$y = \beta_0 + \sum_{j=1}^n \beta_j x_j + \sum_{j=1}^n \beta_{jj} x_j^2 + \sum_{j < j'}^{n,n} \beta_{jj'} x_j x_{j'} + \varepsilon \quad (2)$$

where:  $\beta$  - regression coefficient,  $x_j$  - monitored parameter,  $n$  - number of parameters

The form of approximation equation:

$$y_0 = \beta_0 + \beta_1 R + \beta_2 F_{pr} + \beta_3 k_p + \beta_4 m + \beta_5 R^2 + \beta_6 F_{pr}^2 + \beta_7 k_p^2 + \beta_8 m^2 + \beta_9 R \cdot F_{pr} + \beta_{10} R \cdot k_p + \beta_{11} R \cdot m + \beta_{12} k_p \cdot F_{pr} + \beta_{13} m \cdot F_{pr} + \beta_{14} k_p \cdot m + \beta_{15} R \cdot F_{pr} + \beta_{16} m \cdot R \cdot k_p + \beta_{17} m \cdot R \cdot F_{pr} + \beta_{18} m \cdot k_p \cdot F_{pr} + \beta_{19} m \cdot F_{pr} \cdot k_p \cdot R + \varepsilon \quad (3)$$

where:  $\beta$  - regression coefficient,  $R$  - monitored parameter ( diameter of driving wheel),  
 $F$  - monitored parameter (initial tension force of track),  
 $k$  - monitored parameter (track geometry),  $m$  - monitored parameter (track link weight),  
 $n$  - number of parameters

4. Final verification of mathematical model

Final verification is provided by comparison of the physical dependence value  $y$  obtained from the measurement and regression function  $y_0$  corresponding point.

#### 5. Conclusion

The paper describes one of the possible ways how to create the computational model of real track vehicle movement mechanism in software environment MSC.ADAMS.AVT. Vehicle track design and recommendation for upgrading mathematical model is emphasised. The objective is to create computation simulation for the purpose of finding the basic information on track component parts and undercarriage performance of moving vehicle.

The similar simulations were already performed. They analysed the influence of changes in reaction force values on axes of supporting rollers depending on changes in weight track link, changes of track radius and sizing changes in initial tension track. Their results approved, that influence of changes of track radius, initial tension and track link weight, on changes of reaction forces on supporting rollers of undercarriage influence are significant and they are worth of further investigation.

This research also confirmed previously published results of simulating calculations analysing influence of changes in driving and track adjusting wheels on required driving wheel torque. Proposed calculations quantify the influence ratio of movement and dynamic loading on elements of vehicle chassis.

One of the main benefits of the proposed analysis is the possibility of determination, which constructional changes can lead to an objective improvement. This can be defined as a track vehicle directional improvement and improvement of maximum speed increase, simulated apart from other factors, not only by track construction, but also by the whole track kinetic and suspension track vehicle undercarriage mechanism.

### Acknowledgement

The research was performed under support of Research plan 0000401 of Faculty of Military Technologies of University of Defence in Brno, Czech Republic.

### References

- ADAMS/MSC/ (2003), Tracked Vehicle Toolkit version 2003.0, Documentation, MSC.Software, Sweden.
- Chalupa, M., Kotek, V., Vlach, R. , (2001) Research of design of vehicle track for high speed. Final report of Research program POV MO 03171100014. VA Brno, pp.1 – 115.
- Chalupa, M., Kratochvíl, C., Kotek, V., Heriban, P. ( 2007) “Computer Method of Analysis of Driving System Dynamic Properties.” In: “AT & P Journal Plus”. Bratislava: HMH s.r.o., 841 02 Bratislava 42, ISSN 1336-5010.
- Chalupa, M. (2007) “Simulation Method of Analysis of Driving System Dynamic Properties”. In: Proceedings of the International conference “48<sup>th</sup> International conference of Departments of Mechanical Engineering”, Smolenice 12.-14.9. 2007“, STU v Bratislavě, SR, 2007, ISBN 978-80-227-2708-2, pp.48 -56.
- Chalupa, M, Veverka, J. , (2007). Dynamic Loading Simulation of Vehicle Track . In: Proceedings of the International conference „Engineering mechanics 2007.“, Svratka, CR, ISBN 978-80-87012-06-2, pp. 82 – 90.
- Chalupa, M, Veverka, J. (2007). “Computerized Dynamic Loading Simulation of Vehicle Track.” In: Proceedings of the International conference „Dynamics of Rigid and Deformable bodies 2007“, Ústí nad Labem, CR ISBN 978-80-7044-914-1, pp. 231 – 238.
- Koucký, M. and Vališ, D. (2011) „Some aspects of sequential systems design.“ In Proceedings 17th ISSAT International Conference on Reliability and Quality in Design. Piscataway : International Society of Science and Applied Technologies,. ISBN 978-0-9763486-7-2, ,pp. 62-66.
- Rolc, S., Adamík, L., Buchar, J., Severa, L. (2008) Plate response to buried charge explosion, Material Science Forum, Vol 566, ISBN 0-87849-465-0, pp. 83-88.
- Vlach, R., Chalupa, M. (2008). The methodology of track mathematical model verification data measuring of tracked vehicle BMP 2, Methodology of measuring, University of Defence Brno, VTUO Slavičín, division Vyškov, CR, ISBN 978-80-7231-608-9, pp. 1 – 15.