

NUMERICAL MODELLING OF THE DESTRUCTION OF REINFORCEMENT BARS IN THE SUPPORTING ZONE OF THE COLUMN

B. Wieczorek*

Abstract: *The destruction of the supporting zone of slab-column structures caused by a breakdown, pulls the upper reinforcement in the course of the dropping down of the roof upwards. The only element which can deter a further catastrophe is the reinforcement at the bottom, which is not torn off, but even pressed against the concrete of the column and the slab. The paper presents the results of laboratory tests performed on a simplified model of a slab-column connection. The aim of investigations was to find out at which value of the load the destruction of such a connection occurs due to the rupture of the bars above the column. Basing on these investigations a numerical model was developed in the ANSYS program. In order to render the conditions of connecting the reinforced concrete element with the reinforcement bars in the case of considerable deformations, the model was divided into finite elements. In modelling the fragment of the connection of reinforcement bars with the concrete and anchoring, the contacting elements were used. The obtained results of laboratory tests and the results of numerical calculations permitted to determine the relations between the exerted load and the displacement of the column in time and also to determine the values of the force at which the breakdown of the bars above the column had taken place.*

Keywords: Reinforced concrete structure, Slab-column connections, Two-way slabs structural integrity reinforcement, Experimental research, Numerical model.

1. Introduction

In the light of investigations carried out so far, the mechanical properties and static behaviour of the concrete and reinforcement in the zone adjacent to the support of slab-column structures are rather well known. The methods of calculations and the principles of design have been elaborated. For the sake of safety precise understanding of the behaviour of this type of these zones of structures in the range of destructive loads is very important. Instructions concerning the prevention of such situations are to be found only in standards: ACI 318 (2004) and CSA A23.3 (2011).

An inadequately constructed supporting reinforcement may result in a complete destruction of the whole structure. Researches have been carried out to investigate the post-failure behaviour of slab-column structures. The results of these tests, and also the technical and engineering procedure of modelling a flat slab of reinforced concrete slab-column structures were presented in literature (Wieczorek M, 2013, 2014). The application of continuous bottom reinforcement was recommended (Mitchell et al., 1979, 1984, 2012) as a practical and economical solution in order to prevent a progressive collapse. The reinforced concrete models of slab-column connections with bottom bars passing through the column have been investigated (Wieczorek B., 2013, 2014). Based on these investigations the reserve of the load capacity of the supporting zone after its destruction due to punching has been accurately estimated.

2. Description of the Problem

In investigations (Wieczorek B., 2013, 2014) a model corresponding to the actual behaviour of a slab-column connection has been applied. Within the frame of these investigations and basing on the obtained results, a simplified model of a slab-column connection could be developed, which can be used to determine the value of the load at which the reinforcement bars will rupture.

* Barbara Wieczorek, PhD. Eng.: Department of Theory of Building Structures, Faculty of Civil Engineering, Silesian University of Technology, Akademicka 5 st.,44-100 Gliwice, Poland, barbara.wieczorek@polsl.pl

The paper presents the results of laboratory tests performed on a simplified model of a slab-column connection (Fig. 1). The aim of investigations was to find out at which value of the load the destruction of such a connection occurs due to rupture of the bars above the column. The simplified model consisted of a column with a cross-section of 400 x 400 mm and a height of 500 mm (Fig. 1), by which passed four bars. In each model a bottom reinforcement crossing above the column was constructed of reinforcing steel class C ($\epsilon_{uk} = 11.8\%$, $f_{tk}/f_{yk} = 1.196$ and $f_{yk} = 547.1$ MPa) (Eurocode 2, 2010). The column was situated axially in relation to the centre of the test stand (Fig. 2).

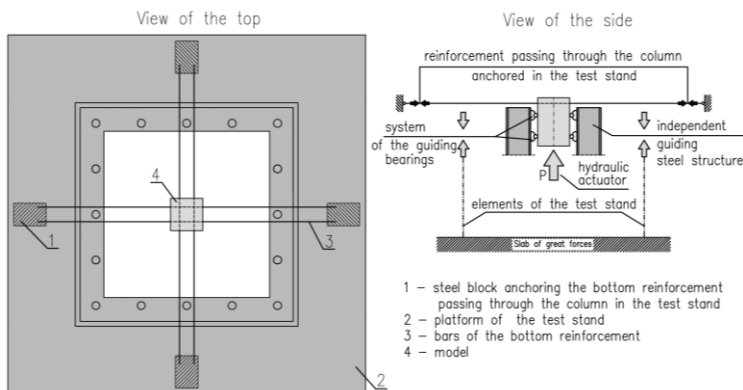

Fig. 1: Diagram of the load exerted on the model.



Fig. 2: Model situated on the test stand during the tests.

3. Numerical Model

Basing on these investigations a numerical model was developed in the ANSYS program (Fig. 3). In order to simulate the connection of the reinforced concrete element with the reinforcement bars in the case of considerable deformations, at the edges of the model bevels were cut in the shape of quarter rounds. In the course of testing, parts of the concrete were loosened and the bars were supported on curved arches.

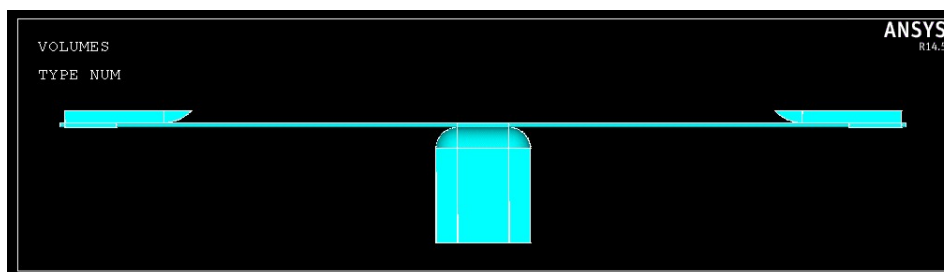

Fig. 3: Numerical model of the analyzed problem.

While constructing the model, great care was paid to an accurate representation of three kinds of the material applied in the investigations, complying with the ANSYS program:

- anchoring - steel - linearly elastic material,
- reinforcement bars - steel - ϵ - σ characteristics in compliance with the diagram,
- column - concrete - linearly elastic material $E = 30$ GPa complying with the tests.

In order to meet the conditions of connecting the reinforced concrete element with the reinforcement bars in the case of considerable deformations, the modal was divided into finite elements, applying the 20-node element SOLID86. In modelling the fragment of the connection of reinforcement bars with the concrete and anchoring, the contacting elements TARGET170 and COUNA174 were used.

Similarly as in the investigations, the load was in the model exerted on the bottom part of the column in one step, divided into substeps, thus obtaining the values of stresses and strains in the nodes of the final elements. Thanks to this, similarly as in the case of the tested model, it was possible to get a diagram of displacements of the column as a function of the load. The range of the resulting maximum displacement in the numerical model is to be seen in Fig. 4.

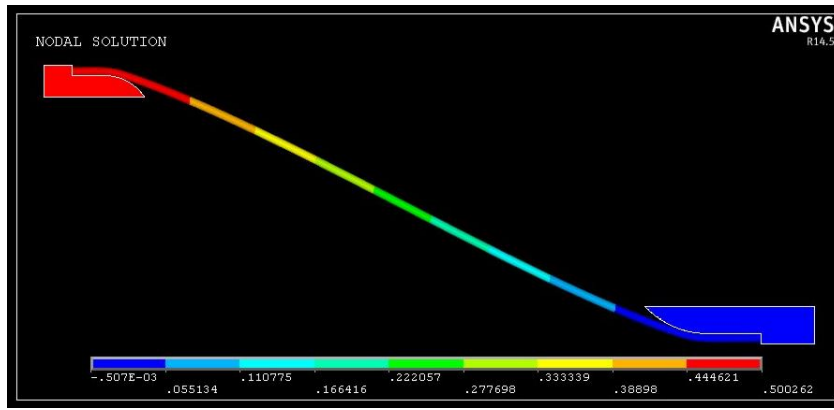

Fig. 4: The range of displacements of the column.

Below there are maps of the distribution of stresses obtained in the last substep of loading preceding the destruction. An exemplary distribution of normal stresses along the axis of the bars in the vicinity of the construction of the bar over the column and at the place the anchoring of the bar have been shown in Fig. 5.

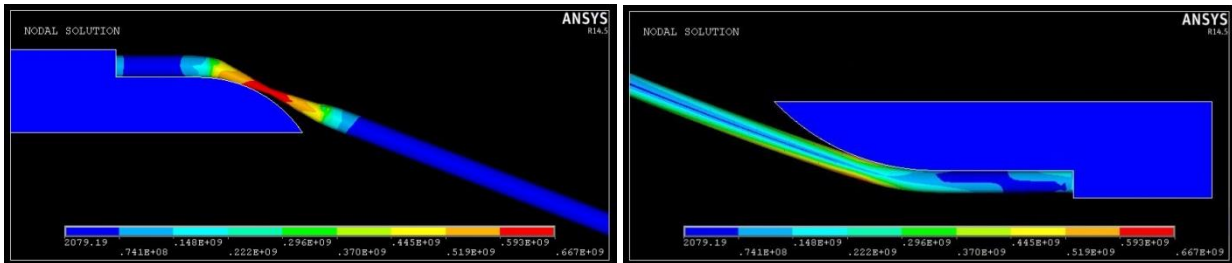

Fig. 5: Map of the stresses: column and anchoring.

4. Synthesis of the Results

The results of laboratory tests and numerical calculations have been compared, permitting to determine the dependence of the displacement of the column on the exerted load (Fig. 6). The values of the forces due to which the corresponding bars above the columns ruptured have been gathered in Tab. 1.

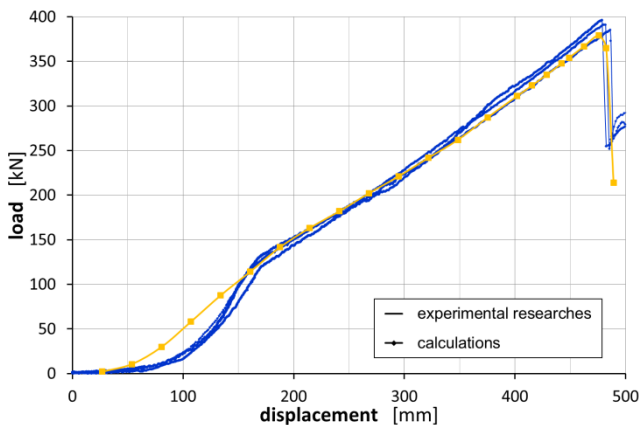

Fig. 6: Graph of changes in the displacement of the column as a function of the load.

Tab. 1: The values of forces and displacements obtained in the tests and the numerical model.

	Tested model	Numerical model
Maximum load obtained in tests	394.96 kN	
	391.17 kN	379.09 kN
	383.91 kN	
Displacement of the column	476 mm	
	481 mm	477 mm
	485 mm	

The difference in the percentage of numerical calculations in relation to the tests is less than 5%. The value of the load causing the rupture of the first bar, calculated numerically, amounts to 95.9%-98.7% of the value of the force obtained by testing the model.

Basing on numerical calculations, the stresses were analyzed which occurred in the bars passing through the column. The values of the stress in the cross-section of the bar at the spot of its considerable constriction (where the bar later ruptured) and in the centre of the span between the column and the anchoring was determined at the moment of reading the highest value of the charging force.

An analysis of the obtained results indicates a considerable effect of bending on the load-bearing capacity of the bars passing through the column. The load-bearing capacity of these bars is additionally affected by their bending by about 9%. Simultaneously, also the values of stresses occurring in the cross-section of the bar have been compared with the tensile strength of the steel. These stresses amounted to 98.78% of the tensile strength f_{tk} .

The values of stresses permitted to determine the degree of the boundary degradation of the axial force in the bar, resulting from the bending of the bar at the point of its contact with the anchoring element of the reinforcement or concrete column. This is of essential importance, because in the solution quoted in the standard (ACI, 2011, CSA, 2004) this phenomenon has been left out of account, and in calculations only the value of the axial force is taken into consideration. The values of the load-carrying capacity $F_{cal} = 439.79$ kN calculated according to standards is higher than the value obtained by testing.

5. Conclusions

Attempts to represent investigative models, the procedure of investigations and the obtained results in computer programs are a rather difficult task, due to the lack of information concerning all the processes encountered in the course of laboratory tests. The comparison quoted above indicates the possibility of constructing a rather good numerical model, which can simulate the aforesaid laboratory tests. The obtained numerical model permits to determine exactly the degree of degradation of the load capacity in reinforcement bars.

References

- ACI Committee 318 (2011) Building code requirements for structural concrete and commentary, American Concrete Institute, United State America.
- CSA Standard A23.3-04 (2004) Design of concrete structures, Canadian Standard Association.
- PN-EN 1992-1-1: 2004/AC (2010) Eurocode 2, Design of concrete structures - Part 1-1: General rules and rules for buildings, European Standard.
- Habibi, F., Redi, E., Cook, W. D., Mitchell, D. (2012) Assessment of CSA A23.3 structural integrity requirements for two-way slabs. Canadian Journal of Civil Engineering, 39.
- Hawkins, N. M., Mitchell, D. (1979) Progressive collapse of flat plate structures. Journal of the American Concrete Institute, 76(7).
- Mitchell, D., Cook, W. D. (1984) Preventing Progressive Collapse of Slabs Structures. Journal of Structural Engineering, 110(7).
- Wieczorek, B. (2013) Influence of the location of the column on the load capacity of a slab-column connection for the inner column after punching, Procedia Engineering, Vol. 57.
- Wieczorek, B. (2013) Idea of a simplified model to determination of the load capacity of and inner slab-column connection after its punching, Procedia Engineering, Vol. 65.
- Wieczorek, B. (2013) Load-bearing capacity of reinforcing bars in the zone of the slab-column connection determined experimentally and in the result of numerical calculations, Procedia Engineering, Vol. 65.
- Wieczorek B. (2014) Experimental tests for the analysis of a load-bearing capacity of an internal slab-column connection after its punching at various positions of the column, Advanced Materials Research „Structural and physical aspects of civil engineering”.
- Wieczorek B. (2014) Load capacity of an internal slab-column connection depending on the geometric parameters of the reinforcement, Advanced Materials Research „Structural and physical aspects of civil engineering”.
- Wieczorek, M. (2013) Influence of amount and arrangement of reinforcement on the mechanism of destruction of the corner part of a slab-column structure, Procedia Engineering, Vol. 57.
- Wieczorek, M. (2013) Investigations concerning the corner part of the reinforced concrete structure in the emergency of removing the corner support, Procedia Engineering, Vol. 65.
- Wieczorek, M. (2013) Concept of shell-beam model of slab-column connection based on analysis of the 3D model, Procedia Engineering, Vol. 65.
- Wieczorek M. (2014) Comparison experimental tests of behavior of the slab-column structure after removal of the corner support with the simplified models describing the mechanism of destruction, Advanced Materials Research „Structural and physical aspects of civil engineering”.
- Wieczorek M. (2014) Narrow reinforced concrete slabs after their flexural destruction, Advanced Materials Research „Structural and physical aspects of civil engineering”.