

DYNAMIC FIELD BALANCING OF SENSITIVE ROTOR

J. Zachwieja *

Abstract: *The paper demonstrates problems arising during the field balancing of sensitive rotor. This term is referred to as rotors of which the response to excitation, expressed as a change of amplitude of vibration parameters, is significant after adding to it even small tested or correction masses.*

Keywords: Dynamic balancing, Resonance vibration, Matrix of influence coefficients, Amplitude-frequency characteristics, Fourier transform.

1. Introduction

A sensitive rotor is referred to as rotor of which response to excitation, expressed as a change of amplitude of vibration parameters, is disproportionately high compared to quantity of excitation. This occurs usually when rotary frequency of rotor is close to critical frequency. Width of interval in which rotor vibrations are approximately resonant, is largely dependent on external anisotropic, i.e. difference in stiffness of the foundation in the vertical and horizontal direction.

Dynamics of asymmetrical rotor with anisotropic bearing was investigated by Black and McTerman (Black and McTerman, 1968). Parkinson (Parkinson, 1968) proved that near the resonant frequency phase angle as well as vibrations amplitude are dependent on localisation of imbalance. Another particularity associated with the stiffness asymmetry of rotor foundation, noticed by Iwatsubo and Nakamura (Iwatsubo and Nakamura, 1968), is a domination in amplitude vibration spectrum for doubled synchronic frequency when its angular speed is equal to a half of critical speed. Gunter and Trumpler (Gunter and Trumpler, 1969) as well as Ehrich (Ehrich, 1992) have done research on the determination of the influence of stiffness anisotropy of foundation on the stability of rotor-bearing system. Black (Black, 1969) and Iwatsubo (Iwatsubo, Tomita, Kawai, 1973) have demonstrated that established vibrations of asymmetric rotor under the conditions of resonance can be unstable.

During analysing the motion of anisotropic rotor Ganesan (Ganesan, 1996; Ganesan, 2000) has stated that asymmetric of bearing stiffness leads to vibration instability if the rotational frequency of rotor is higher than frequency of its proper vibrations respectively in directions: horizontal (x) and vertical (y). Stable vibrations of rotor in x direction prevail in the range of the resonant frequency. At the rotor speed close to the critical speed, vibrations in x direction are more stable through effects of imbalance as well as asymmetric of systems which at the same time cause motion destabilisation in y direction. The effect of non-monotonic trend of increase or decrease in the vibration amplitude, inducted by imbalance, is strongly dependent on scale of foundation stiffness anisotropy.

2. Analysis of the Resonant Vibration of Radial Fan

Susceptibility of foundation and foundation of the body mainly determine natural vibrations of rotating machines because the body and rotor of the machine are usually rigid bodies. Derogation from this rule may occur for small fans which housings, in the form of box, are made of thin sheet.

Such fan was tested because during a test of balancing its rotor, there has been reported very high sensitivity to the test mass which has been attached to the disk. The orientation of fan body on the platform using rubber mat as a vibration isolator may suggest anisotropic stiffness of foundation, the

* Assoc. Prof. Janusz Zachwieja, PhD.: Department of Applied Mechanics, University of Technology and Life Sciences in Bydgoszcz, Kaliskiego 7, Bydgoszcz; Poland, janusz.zachwieja@utp.edu.pl

consequence of which should be rotor vibrations with greater amplitudes in vertical and horizontal direction.



Fig. 1: View of the fan and its model.

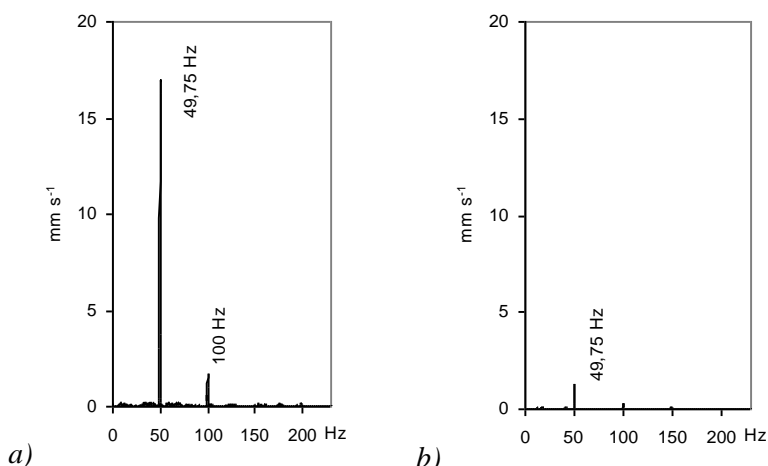

Fig. 2: Amplitude-frequency characteristics of rotor vibration velocity in direction: a) horizontal, b) vertical.

The rotor disk, with a mass of ~ 30 kg, is located on the motor shaft. Rotating speed of rotor is $2950 \text{ r}\cdot\text{min}^{-1}$. Ultra-harmonic rotational frequency of the motor on the vibration spectrum suggests that the system vibrations are non-linear. Similar situation occurs in the case of clearance in the foundation system of the rotor or the near resonant frequency.

Both cases represent a significant impediment to the process of the rotor balancing by using coefficient matrix of influence method (Zachwieja, 2011, 2012). Testing the characteristic of rotor vibrations allows choosing the most effective way of balancing. Removing the rotor from the resonant vibrations can be done by changing the rotational velocity of the rotor, which is the simplest and the most effective procedure, or by changing the stiffness of system. Changing mass is the most rarely used.

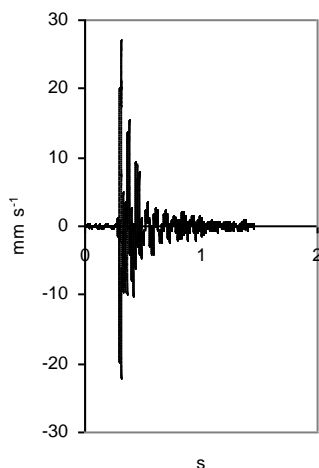

Fig. 3: Time course of system response to the impulse excitation.

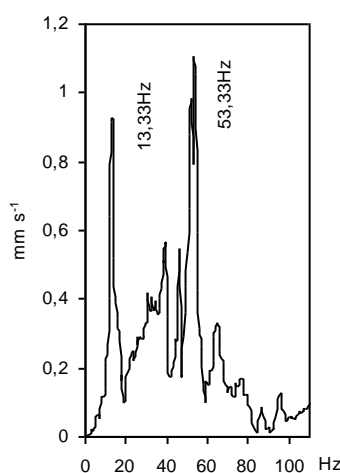

Fig. 4: Characteristic of resonant vibrations of rotor.

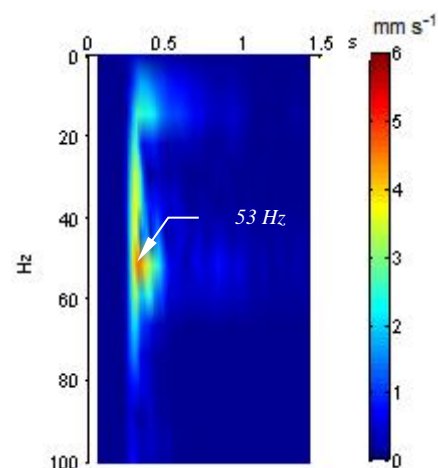

Fig. 5: Image of short-time Fourier transform of rotor vibration velocity.

Testing the characteristic of rotor vibrations was brought to the designation of its resonant characteristic by impulse excitation. Based on the time course of system response to the impulse excitation (Fig. 3) it can be concluded that there is a damping with a relatively high value. It means that stiffness of the rotor foundation is specific.

Amplitude-frequency characteristic of the response indicates the possibility of appearance of a number of critical frequencies, of which 13.3 Hz and 53 Hz have the main influence on rotor vibrations (Fig. 4). 53 Hz frequency is close to rotational frequency of the rotor (Fig. 5).

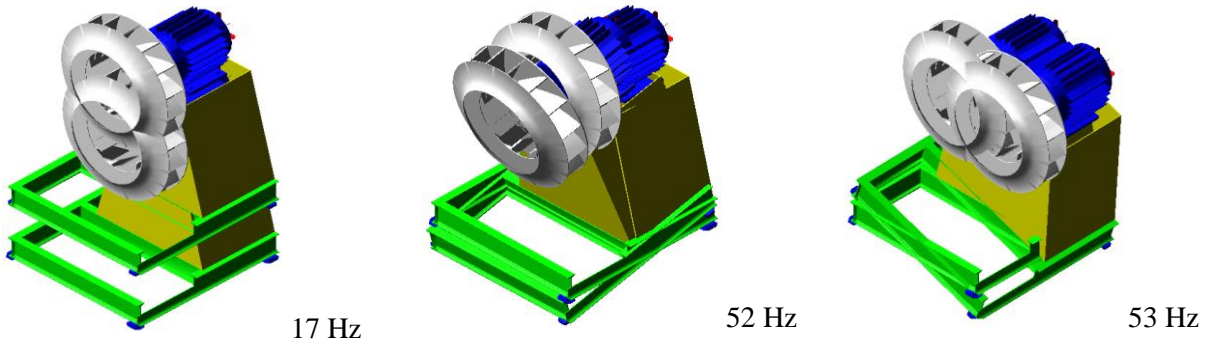

Fig. 6: The time course of system response to the impulse excitation.

Numerical analysis confirmed that the free vibration frequency of the rotor with parameters such as those of tested object, may correspond to the measured values (Fig. 6). Simultaneous input vibrations with the frequency of 52 Hz and 53 Hz cause that the vibrations with the highest amplitudes will be measured on a motor bearing on the side of winding cooling disk. Rotor balancing requires two corrections. One of them should be rotor disk, the second one should be cooling disk of rotor. However, the second one cannot be used for this purpose because of low stiffness and diameter.

3. Fan Rotor Balancing by Using the Optimisation Amplitudes of Vibration Method in the Directions of Measurement

According to coefficients matrix of influence method, it is assumed that there is a relation between force of rotor imbalance and vector of selected vibration parameter:

$$\mathbf{N}_n = \mathbf{A}\mathbf{F}_n \quad (1)$$

where: \mathbf{F}_n – imbalance force, \mathbf{N}_n – vector of selected vibration parameter for rotational frequency of rotor, \mathbf{A} - coefficients matrix of influence.

For rotor with an external anisotropic, the proper way of solving the balancing problem is a technique used by the author. It consists in optimising distribution of vibration amplitudes in a way that it will be the lowest for the selected directions of measurements. At a specific correction planes and unlimited number of measurement planes, coefficients matrix of influence is not a square matrix which means that inverse matrix to \mathbf{A} matrix does not exist. However, there is a possibility of obtaining a solution to the equation (1) in the terms of optimisation. One way is to define Moore-Penrose pseudoinverse of matrix which can be used as \mathbf{A}^{-1} inverse matrix if the inverse matrix does not exist. $\mathbf{A}^* \in \mathbf{R}^{n \times m}$ matrix is going to be pseudoinverse matrix for \mathbf{A} matrix if the condition $\mathbf{A}\mathbf{A}^*\mathbf{A}=\mathbf{A}$ is satisfied. Pseudoinverse matrix application causes that vector:

$$\mathbf{F}_n^* = \mathbf{A}^*\mathbf{N}_n \quad (2)$$

minimises the norm $\|\mathbf{A}\mathbf{F}_n - \mathbf{N}_n\|^2$. Therefore, instead of the equation (1) we will use the formulation:

$$\mathbf{F}_n = \mathbf{A}^*\mathbf{N}_n \quad (3)$$

which allows determining imbalance vector.

Disk rotor balancing shows its high sensitivity to the change in value of correction masses which is characteristic for the near resonant frequency. Location of correction mass was not stable which is also symptomatic for resonant frequency. However, the use of optimising method resulted in a decrease of the vibration amplitude of cooling disk of rotor bearing which demonstrates its high value with slight increase of vibration amplitudes in the rotor disk bearing.

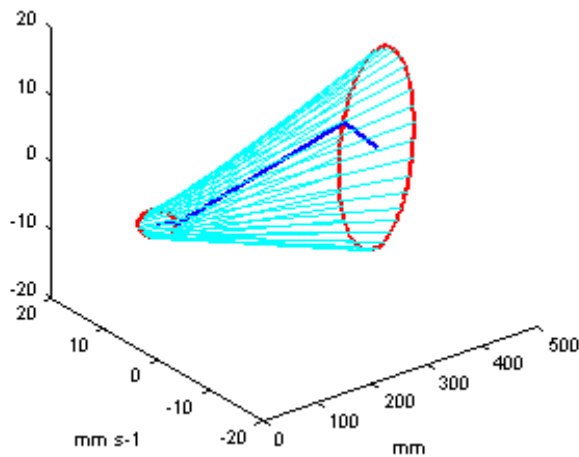

Fig. 7: 3D-holospectrum of rotor vibration velocity before balancing.

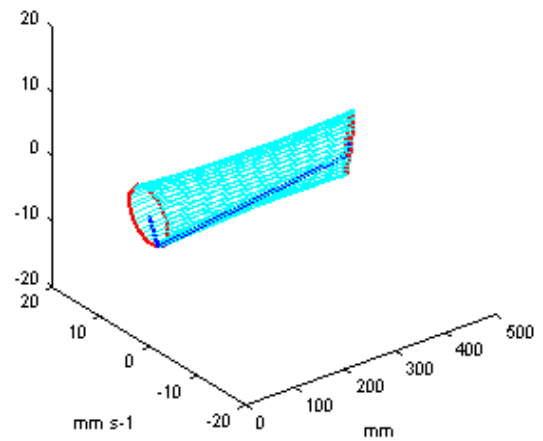

Fig. 8: 3D-holospectrum of rotor vibration velocity after balancing with correction mass 7.5 g.

4. Conclusions

Coaxial rotor with a high static imbalance compared to its mass can be balanced to some extent even in the resonant area. Achieved balance efficiency under the resonance conditions is usually worse than balancing outside those areas.

Coefficients matrix method is sensitive to the proximity of the resonance area of rotor. Correction masses calculated in resonant vibration areas, based on the classic coefficient matrix of influence method, can cause increase in rotor imbalance. Discussed case proves that using a proper optimisation allows an improvement of the dynamic rotor even under resonant vibrations.

References

- Black, H. F. (1969) Parametrically excited lateral vibrations of an asymmetrically slender shaft in asymmetrically flexible bearings. *Journal of Mechanical Engineering Science*, 11, pp. 57-67.
- Black, H. F., McTernan, A. J. (1968) Vibration of a rotating asymmetric shaft supported in asymmetric bearings. *Journal Mechanical Engineering Sciences*, 10(3), pp. 252-261.
- Ehrich, F. F. (1992) Observations of subcritical superharmonic and chaotic response in rotor dynamics, *ASME Journal of Vibration and Acoustics*, 114, pp. 93-100.
- Ganesan, R. (1996) Dynamic response and stability of a rotor-support system with non-symmetric bearing clearances. *Mechanism and Machine Theory*, 6(31), pp. 781-798.
- Ganesan, R. (2000) Effects of bearing and shaft asymmetries on the instability of rotors operating at near-critical speeds. *Mechanism and Machine Theory*, 35, pp. 737-752.
- Gunter, E. J., Trumpler, P. R. (1969) The influence of internal friction on the stability of high speed rotors with anisotropic supports. *ASME Journal of Engineering for Industry*, 91, pp. 1105-1113.
- Iwatsubo, T., Nakamura, M. (1968) Balancing of flexible rotors with asymmetric shaft stiffness. *Memoirs of the Faculty of Engineering Kobe University* No. 15.
- Iwatsubo, T., Tomita, A., Kawai, R. (1973) Vibrations of asymmetric rotors supported by asymmetric bearings. *Ingenieur Archive*, 42, pp. 416-432.
- Parkinson, A. G. (1965) On the balancing of shafts with axial asymmetry. *Proceedings Royal Society of London, Series A* 259, pp. 1095-1098.
- Zachwieja, J. (2011) The Influence of Rotor Foundation Stiffness on operating and Balancing Efficiency with Near Resonant Velocity. *Studia i Materiały Polskiego Towarzystwa Zarządzania Wiedzą*, 48, pp. 148-161 (in Polish).
- Zachwieja, J. (2012) Rotor Balancing of the Radial Fan under Different Dynamic States. Habilitation thesis No. 153, Wydawnictwo UTP (in Polish).