

NUMERICAL ANALYSIS OF THE MODAL PROPERTIES OF A SHROUDED TURBINE BLADING

J. Brůha^{*}, V. Zeman^{**}

Abstract: Presented work is concerned with the numerical analysis of natural frequencies and corresponding mode shapes of twisted blades with contacts between blade shrouds. The blades are modelled by means of the Finite Element Method (FEM) using Rayleigh beam elements with varying cross-sectional parameters along the elements and six degrees of freedom (DOFs) in each of nodes, while the rhomboid-shaped shrouds are considered to be rigid. The blades are clamped into a rotating rigid disk. Since the finite element models based on the Rayleigh beam theory tend to slightly overrate natural frequencies and underrate deflections in comparison with finite element models including shear deformation effects, parameter tuning of the blades is performed. The modelling of interactions at the contact surfaces of neighbouring blade shrouds is carried out using a multipoint frictionless contact approach with constant normal contact stiffness. In order to compare the natural frequencies, three different geometries of the blade shroud as well as three different values of the pre-twist angle induced by preloads at the contact interfaces are tested.

Keywords: Turbine blade, Finite element method, Parameter tuning, Contact, Modal analysis.

1. Introduction

Turbine blades are the most important parts of gas and steam turbines. Due to the crucial role they play during the operation, blades and bladed disks require special attention and very careful design. One of the key factors that affect service life of turbine blades is associated with vibration prevention techniques. Blade vibration as a side effect of the operation of steam and gas turbines is very dangerous because of the high cycle fatigue. The failure of a single blade can be responsible for large economic losses or, in the worst-case scenario, even a human loss. Since prediction of all excitation sources is very difficult, the blades should be designed in such a way that they can absorb vibration caused by unexpected or unusual excitation. One of the most effective types of damping devices is a blade shroud. When surfaces in contact of the neighbouring blade shrouds move relative to each other, the rubbing dissipates energy (Pešek et al., 2015; Petrov, 2008; Zeman et al., 2010). Moreover, the blade shrouds stiffen the blading and, in consequence, they affect natural frequencies of a bladed disk.

Today, a large-scale FE model of a bladed disk contains $10^4 - 10^6$ DOFs (Petrov, 2008). However, utilization of these models can be, especially in cases of large contact problems, inefficient because of the time-consuming computation. Therefore, the blade modelling by means of various types of beam FEs can be perceived as a suitable alternative.

In this paper, a method for the numerical analysis of modal properties of shrouded turbine blades has been developed. The method is based on a blade modelling by means of Rayleigh beam FEs with varying cross-sectional parameters along the FEs (Brůha & Rychecký, 2016). In order to attenuate the handicap of overrated natural frequencies due to omitted shear deformation effects in Rayleigh beam theory, parameter tuning is performed. The interactions between neighbouring blade shrouds are modelled using a multipoint frictionless contact model (Hajžman & Rychecký, 2012). As a test example, the effects of three different geometries of the blade shroud and three different values of the pre-twist angle (induced by preloads at the shroud contact interfaces) on the natural frequencies are analysed.

^{*} Ing. Jan Brůha: Department of Mechanics, Faculty of Applied Sciences, University of West Bohemia, Univerzitní 22, 306 14, Plzeň, CZ, bruhaj@ntis.zcu.cz

^{**} prof. Ing. Vladimír Zeman, DrSc.: Department of Mechanics, Faculty of Applied Sciences, University of West Bohemia, Univerzitní 22, 306 14, Plzeň, CZ, zemanv@kme.zcu.cz

2. Computational modelling of interacting blades

In the framework of the computational modelling using FEM, we consider a model of M twisted blades with variable cross-section along the blades and rigid rhomboid-shaped tip shrouds (see Fig. 1). The blades are clamped into a rigid disk rotating with constant angular velocity ω_0 around the Y axis. As noted previously, the blades are divided into $N - 1$ Rayleigh beam finite elements (blade finite elements) with varying cross-sectional parameters along each FE and six DOFs in each of the nodes on rotating x_j axis, $j = 1, 2, \dots, M$. Due to zero displacements in the first node of each blade, described model has $n = 6M(N - 1)$ DOFs.

The equations of motion of the individual blades can be expressed in generalized coordinates

$$\mathbf{q}_j = [\dots u_i, v_i, w_i, \varphi_i, \vartheta_i, \psi_i, \dots]^T, \quad i = 1, 2, \dots, N, \quad j = 1, 2, \dots, M \quad (1)$$

in following form

$$\mathbf{M}_j \ddot{\mathbf{q}}_j + (\mathbf{B}_j + \omega_0 \mathbf{G}_j) \dot{\mathbf{q}}_j + [\mathbf{K}_{s,j} + \omega_0^2 (\mathbf{K}_{stiff,j} - \mathbf{K}_{\omega,j})] \mathbf{q}_j = \mathbf{0}, \quad (2)$$

where symmetric matrices \mathbf{M}_j , \mathbf{B}_j , $\mathbf{K}_{s,j}$, $\omega_0^2 \mathbf{K}_{stiff,j}$, $-\omega_0^2 \mathbf{K}_{\omega,j}$ are mass, material damping, static stiffness, centrifugal stiffening under rotation and softening because of modelling in the rotating coordinate system, respectively. The skew symmetric matrix $\omega_0 \mathbf{G}_j$ represents gyroscopic effects. Since the Rayleigh beam theory does not take account of shear deformation effects, turbine blade models based on this approach tend to slightly overestimate natural frequencies and underestimate deflections. In order to attenuate this handicap, the Young's modulus E as well as the torsion resistance J_t were being tuned (Brůha & Rycheký, 2016).

In order to include the mutual interactions between the neighbouring blade shrouds, a multipoint frictionless contact model is taken into account. In such a case, the rectangular contact areas are decomposed into a set of elementary contact areas (marked with the subscript e) and the contact forces are distributed among them. The coupling stiffness matrix \mathbf{K}_C of all M interacting blades can be derived from the strain energy (Zeman et al., 2010)

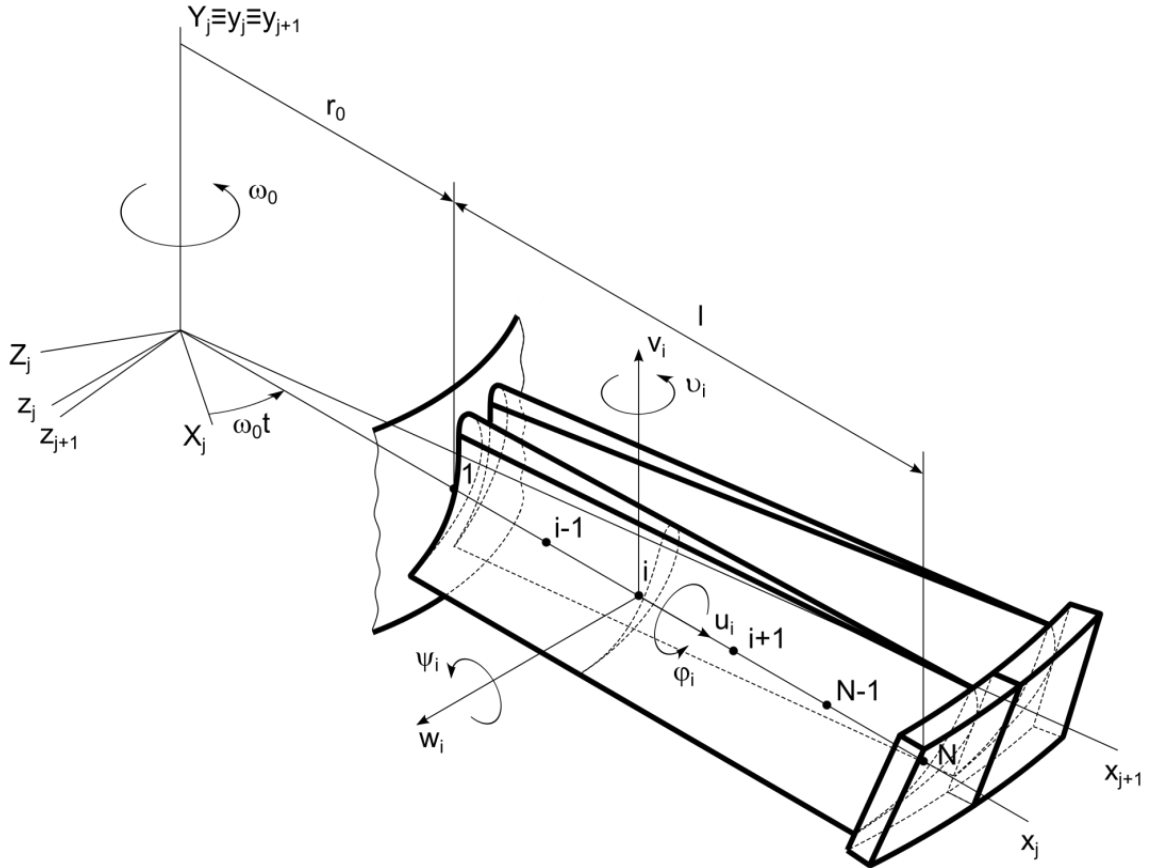

Fig. 1: A sector of a bladed disk.

$$E_S = \frac{1}{2} \sum_{j=1}^M \sum_e k_{j,e} d_{j,e}^2, \quad (3)$$

where $k_{j,e}$ represents normal contact stiffness in e th elementary contact area of interaction between the j th and the $(j + 1)$ th blade and $d_{j,e}$ is relative displacement of the elementary contact areas in normal direction. Subscript $j = M$ corresponds to interaction between the M th and the 1st blade. Then, the coupling stiffness matrix is given by the equivalence

$$\frac{\partial E_S}{\partial \mathbf{q}} = \mathbf{K}_C \mathbf{q}, \quad \mathbf{q} = [\mathbf{q}_1^T, \mathbf{q}_2^T, \dots, \mathbf{q}_M^T]^T. \quad (4)$$

Finally, the equation of motion of the whole structure (of M interacting blades) can be written in the form

$$\mathbf{M} \ddot{\mathbf{q}} + (\mathbf{B} + \omega_0 \mathbf{G}) \dot{\mathbf{q}} + [\mathbf{K}_s + \omega_0^2 (\mathbf{K}_{stiff} - \mathbf{K}_\omega) + \mathbf{K}_C] \mathbf{q} = \mathbf{0}. \quad (5)$$

In accordance with equation of motion (2), below presented matrices have a block-diagonal structures

$$\begin{aligned} \mathbf{M} &= \text{diag}(\mathbf{M}_1, \dots, \mathbf{M}_M), \quad \mathbf{B} = \text{diag}(\mathbf{B}_1, \dots, \mathbf{B}_M), \\ \mathbf{G} &= \text{diag}(\mathbf{G}_1, \dots, \mathbf{G}_M), \quad \mathbf{K}_s = \text{diag}(\mathbf{K}_{s,1}, \dots, \mathbf{K}_{s,M}), \\ \mathbf{K}_{stiff} &= \text{diag}(\mathbf{K}_{stiff,1}, \dots, \mathbf{K}_{stiff,M}), \quad \mathbf{K}_\omega = \text{diag}(\mathbf{K}_{\omega,1}, \dots, \mathbf{K}_{\omega,M}). \end{aligned} \quad (6)$$

3. Numerical results

The presented method was tested on a bladed disk consisting of 100 steel turbine blades MTD30 stage HP15 (Kubin & Hlous, 2013). For this purpose, an in-house code in MATLAB computing environment was developed. Either of the blades was divided into six Rayleigh beam finite elements and each of the shroud contact surfaces was decomposed into a set of 100 elementary contact areas. In order to compare calculated natural frequencies, three different values of the pre-twist angle (see Table 1) and three different geometries of the blade shroud were considered. As shown in Table 1, the pre-twist of the blades induced by preloads at the shroud contact interfaces has a positive effect on blading stiffening.

Tab. 1: Natural frequencies of the blading.

Family number	Pre-twist angle (°)	Natural frequency (Hz)	
		$\omega_0 = 0$ (rev/min)	$\omega_0 = 5\,500$ (rev/min)
1	0.1	1 129.3 — 2 661.0	1 152.0 — 2 671.3
	0.466	1 129.4 — 2 661.2	1 152.1 — 2 671.4
	1	1 129.4 — 2 661.2	1 152.1 — 2 671.4
2	0.1	2 680.4 — 3 895.5	2 690.6 — 3 895.8
	0.466	2 681.2 — 3 898.3	2 691.4 — 3 898.6
	1	2 681.4 — 3 899.0	2 691.6 — 3 899.3
3	0.1	5 849.0 — 6 380.8	5 868.0 — 6 402.9
	0.466	5 904.9 — 6 386.8	5 924.5 — 6 409.0
	1	5 918.7 — 6 388.1	5 938.5 — 6 410.3

The natural frequencies (and corresponding mode shapes) of the turbine blading are grouped into several distinct families. Each family is characterized by a certain number of nodal circles (NCs) and the mode shapes in the family have from 0 to $\frac{M}{2} = 50$ nodal diameters (NDs). Chosen mode shapes of the considered turbine blading are shown in Fig. 2. In Fig. 2(c), the nodal diameters pass between each two neighbouring blades.

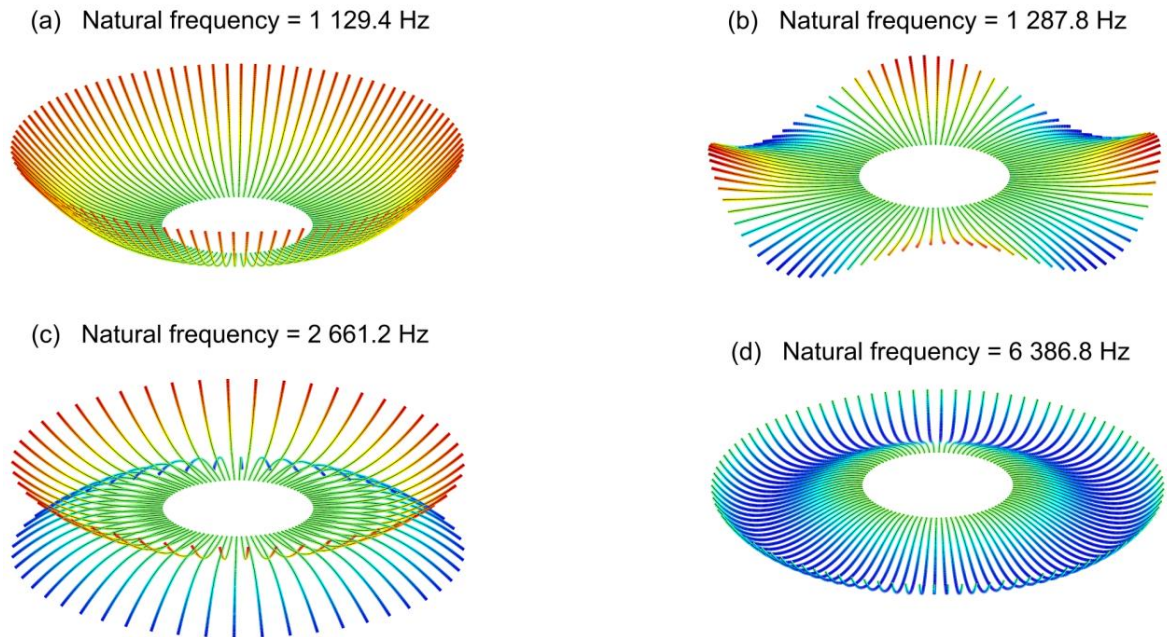

Fig. 2: Chosen mode shapes characterized by: (a) 0 NDs / 0 NCs, (b) 4 NDs / 0 NCs, (c) 50 NDs / 0 NCs, (d) 0 NDs / 1 NC.

4. Conclusions

Presented method deals with the numerical analysis of modal properties of interacting turbine blades. The twisted blades with variable cross-sectional parameters were modelled by means of the FEM using Rayleigh beam elements, while rhomboid-shaped tip shrouds were considered to be rigid. In order to attenuate the handicap of overrated natural frequencies due to omitted shear deformation effects in Rayleigh beam theory, parameter tuning was performed. The interactions between neighbouring blade shrouds were modelled using a multipoint frictionless contact model. The developed in-house code in MATLAB computing environment is capable to analyse the effects of the shroud geometry and the pre-twist angle (induced by preloads at the shroud contact interfaces) on natural frequencies as well as visualize corresponding mode shapes. Described methodology can be perceived as an alternative to complex commercial codes especially due to less time-consuming computation. It is the first step in the analysis of the tip shroud design effect on the dynamic behaviour of a turbine blading with contact interfaces.

Acknowledgement

This work was supported by the project LO1506 of the Ministry of Education, Youth and Sports of the Czech Republic and by the project TE01020068 “Centre of research and experimental development of reliable energy production” of the Technology Agency of the Czech Republic.

References

- Brůha, J. & Rychecký, D. (2016) Modelling of rotating twisted blades as 1D continuum, in: Applied Mechanics and Materials 821, pp. 183-190.
- Hajžman, M. & Rychecký, D. (2012) Multipoint contact approach to the analysis of interacting flexible bodies vibration, in: Advances in Mechanisms Design 8, pp. 181-186.
- Kubín, Z. & Hlous, J. (2013) Measurement of rhombic bladed disk. Research report, Doosan Škoda Power, Pilsen.
- Pešek, L., Hajžman, M., Půst, L., Zeman, V., Byrtus, M. & Brůha, J. (2015) Experimental and numerical investigation of friction element dissipative effects in blade shrouding, in: Nonlinear Dynamics 79, pp. 1711-1726.
- Petrov, E.P. (2008) Explicit finite element models of friction dampers in forced response analysis of bladed disks, in: Journal of Engineering for Gas Turbines and Power 130.
- Zeman, V., Byrtus, M. & Hajžman, M. (2010) Harmonic forced vibration of two rotating blades with friction damping, in: Engineering Mechanics 17, pp. 187-200.